

Orientalmotor

Brushless Motors
BLE2 Series

All New.

An advanced Brushless DC package,
which is both easy to use and feature rich.



Evolution in Brushless Motors

Introducing the BLE2 Series

BLE Series models have been fully revamped. The motor, driver, and cable have been redesigned. While retaining the original advantages of the brushless DC motors. This makes the **BLE2** Series easy to use and highly functional. This advanced model reveals its excellence with every application.



NexBL is the new brushless motor from Oriental Motor.

All of the structures have been updated, with a focus on maximizing the performance demanded of a motor. A combination of unprecedented compactness, high power, and high efficiency has been realized.



200 W



300 W



30 W



60 W



120 W

Superb Performance and Features

- Speed Control Range 80~4000 r/min
- Speed Regulation Rate $\pm 0.2\%$ *In digital setting
- Torque Limiting Capability
- Multiple Speed-Change Operation Max. 16 Speeds
- Output Shaft Holding when Stopped (up to 50% of rated torque)
- Watertight and Dust-Resistant (degree of protection IP66) *Only for motor
- High Rust-Proof and Anti-Corrosion Properties due to Stainless Steel Shaft
- Monitoring and Testing Features which are Useful for Setup and Trouble Shooting.

Easy to Use and Affordable Prices

- The Driver can be Digitally Set and Controlled via the Drivers Front Panel.
- Compact and Thin Drivers Allows for Side-by-Side Installation
- Speed Setting Via PC and External Signals
- Cables with Selectable Pull-out Directions
- A Max. Distance of 20 m between the Motor and the Driver is Possible, via Direct Connection.
- Product Line 30 W~300 W

Features of the Brushless Motor

Brushless DC motors are without brushes, which is a major drawback of brushed DC motors, this allows for quieter and maintenance free operation. Because the **BLE2** Series has a permanent magnet it allows for a compact design with high power and high efficiency.

Wide Speed Control Range

Brushless motors have a wider range of speed control than AC motors. Additionally they are ideal for applications that require a constant torque from low to high speed.

Product Group	Speed Control Range*	Speed Ratio
Brushless Motors BLE2 Series	80~4000 r/min	1:50
Inverter-Controlled Three-Phase Induction Motor	200~2400 r/min	1:12
AC Speed Control Motors	50 Hz : 90~1400 r/min 60 Hz : 90~1600 r/min	1:15 1:17

*Speed control range varies from model to model.

Stable Speed Control

Brushless motors constantly monitors feedback signals from the motor and adjusts the applied voltage by comparing them against the set speed. This allows the motor to rotate at a stable speed from low to high speeds even when the load fluctuates.

- Comparison of Speed Variation (Reference value)

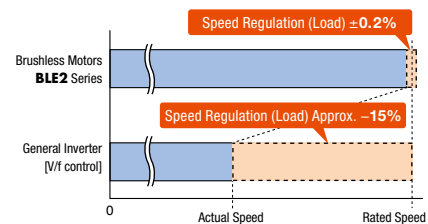

Slim, Light, High Power

Brushless motors are slim, light and high power because permanent magnets are used in the rotor portion. It contributes to the downsizing of equipment.

[Comparison Example at 200 W Output Power]

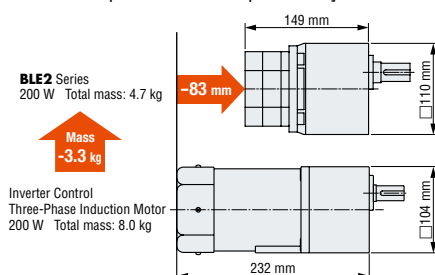

Saves Energy

Brushless motors significantly reduce power consumption as the use of permanent magnets in the rotor portion prevents secondary loss from the rotor. This helps the equipment to save energy.

- Rated Output Power At 50 Hz (Representative value)

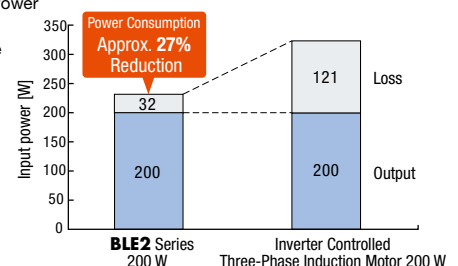

In Pursuit of Easy Setting, Installation, and Wiring

Overhauling the motor structure has made it even more compact, as well as increasing the power and efficiency. The driver comes with a digital indication panel, that easily allows speed to be set via a single potentiometer. Additionally, connection cables now come with the option to choose the pull-out direction and a max. distance of 20 m can be secured via direct connection.

BLE2 Series epitomises what the customers find easy to use.

The Control Panel allows for easy setting.

A control panel is installed on the front face of the drive. Operating data and parameters can be set via operation key and setting dial, whilst looking at the digital display.



*The control panel cannot be removed from the driver.

Quick and Accurate Wiring and Connection

Use of a spring-type connector allows for quick and accurate wiring.



Effective Utilization of Installation Space

This new driver has a compact and slim body through optimal layout of its internal parts. Multiple drivers can now be installed in contact with each other, making it possible to reduce the amount of installation space or increase the number of axes within the same equipment space.

● Compact, Slim-Body Driver

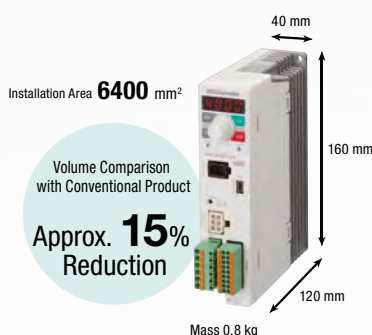

● Side-by-Side Installation of Multiple Drivers

Conventional **BLE** Series Drivers



BLE2 Series Drivers

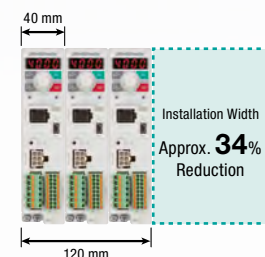

Condition for Contact Installation

- Ambient temperature 0 ~ +40 °C
- Please install it on a heat sink (Material: Aluminum, equivalent to 350×350×2 mm).

Watertight and Dust-Resistant Performance (Degree of protection IP66)

A new type of connector has been designed, which includes a built-in Gasket and O-ring. This allows for the motor to achieve an IP66 degree of protection in both the motor and connector, enabling it to be used in an environment where high pressured water may be an issue. Additionally the connectors lock lever does not require a screw fitting, which allows for easy connection. *The driver portion is IP20.

Connector Structure

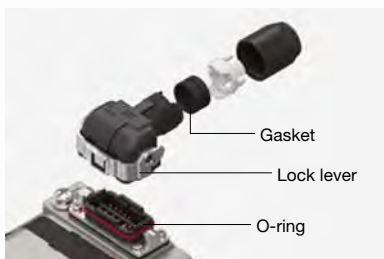

Installation Method



Standardized Use of Stainless Steel Shaft

EURONORM X 10 CrNiS 18 9 stainless steel is used for the shaft, which has excellent anti-corrosive properties. Stainless steel is also used in parallel keys and installation screws.

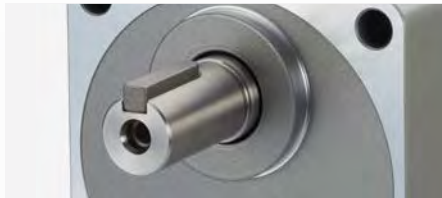

Easy Assembly with a Combination Type

With cutting-processed boss section and installation surface, the installation precision between the device and gearhead has been improved. This improved machining as also resulted in a quieter product. Furthermore, as the combination type of the motor and gearhead comes pre-assembled, it is fast and simple to directly couple onto a device.

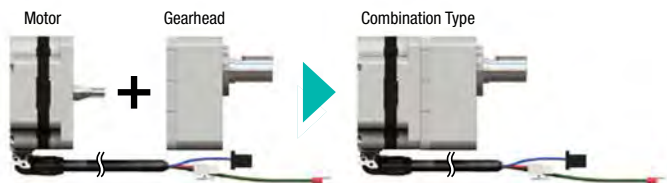

Selectable Pull-out Direction and Directly Connectable Cables

2 types of connection cables are available based on the desired pull-out direction. Since 1 connection cable can be used to connect the motor and the driver directly, with a max. distance of 20 m, there is no need for special connectors.

Selectable Cable Pull-out Direction

Pull-out on output shaft side Pull-out on rear of the motor Vertical Pull-out



*Only pull-out on the rear of the motor is available for round shaft type.

Connection with 1 Connection Cable, No need for Relays

Because only 1 cable is required for the power line, signal line, and ground wire, wiring process can be reduced.



Meeting Customer Needs with Enhanced Functions

Features 4 data setting methods and various functions that are customisable.
 By using data setting software, equipment start-up and checking operating status is simple.
 Oriental Motors offers functions that meet the customers' needs and situations.

Operating Method

- Local Control Operating: Set via the front control panel. It can be used for test operation.
- Remote Control Operation: Set via external signals and data setting software **MEXE02**.

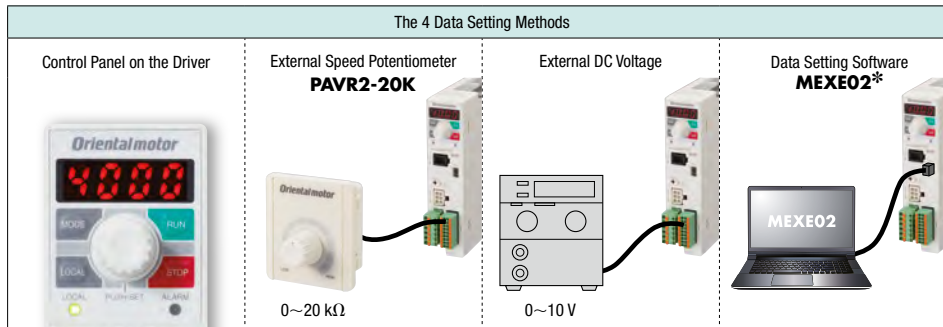

*When using data setting software **MEXE02**, a commercially available USB cable can be used to connect the driver and PC.

Settable Contents

Setting Contents	Applications and Purposes	Setting Value	Setting Method			
			Control Panel	External Speed Potentiometer PAVR2-20K	External DC Voltage	Data Setting Software MEXE02
Speed	For operating at an arbitrary speed.	80~4000 r/min	●	●	●	●
Torque Limiting	For suppressing the motor's max. output power for safety purpose or limiting it depending on the load.	0~300 %	●	●	●	●
Acceleration/Deceleration Time	For setting the acceleration time and deceleration time to prevent impact to the load when starting and stopping.	0~15.0 seconds	●	—	—	●
Multistep Speed-Change Operation	For operating at more than 2 speeds.	Max. 16 speeds	●	—	—	●
Parallel-Motor Operation	For operating multiple motors at the same speed.	20 units max. (When using a potentiometer)	—	●	●	—

Main Software Functions

Below are the major functions that can be operated using the control panel and data setting software **MEXE02**.

Applications and Purposes	Function	Description
Checking the Motor's Generated Torque.	Load Factor Indication	It displays the load factor with the motor's rated torque as 100 %. (Indication range: 0~300 %)
Displays the Output Shaft Speed after the Gearhead.	Gear Ratio	When the gear ratio is set, it displays the converted speed.
Operating at a Speed within the Set Speed Control Range.	Speed Limits Setting	It sets the upper and lower limit values of the speed.
Changing the Speed while the Motor is Rotating.	Speed Teaching	Speed can be changed in the monitor mode while the motor is rotating.
Holding the Load during Standstill.	Easy Holding Torque	An electrical holding torque can be generated while the motor is stopped. (Holding force up to 50 % of rated torque) Note Since the holding force is canceled when the power supply to the driver is turned OFF, it cannot be used to prevent falls during standstill.
Reducing Shock during Starting and Stopping.	Shock Alleviation Filter	This function softens acceleration and deceleration so that the load being transported does not experience sudden movement.
Checking the Reason for the Alarm Generation.	Alarm	Alarm outputs include overload, incorrect connection, over voltage etc and can be identified easily. This allows for ease of fault finding and swift corrective action.
Information Status of the Motor and Driver.	General Information	Before an alarm is output, an information output can be set to enable maintenance teams to be made aware of situations when the motor maybe running outside of its normal conditions before going into alarm.
Set Data is Protectable.	Edit Lock	Set data is protectable, which prevents users from deleting or making unnecessary changes to data & parameters, from either the control panel or the local PLC.

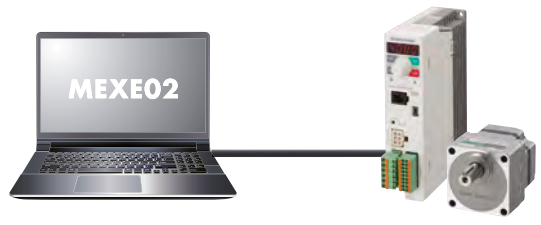

Data Setting Software MEXE02

The data setting software can be downloaded from the website. Oriental Motor also provides it on a CD-ROM free of charge.

Useful Functions that Utilize Data Setting Software MEXE02

Monitoring Function

A variety of monitoring functions are built into the driver that helps with confirming the operating status of the motor, etc. By using these during application set-up, equipment can be configured and adjusted more quickly as well as making maintenance much more efficient.

● **Waveform Monitoring**

At Set-up

The operating and output signal status of the motor can be monitored like an oscilloscope. This can be used for application set-up & configuration.

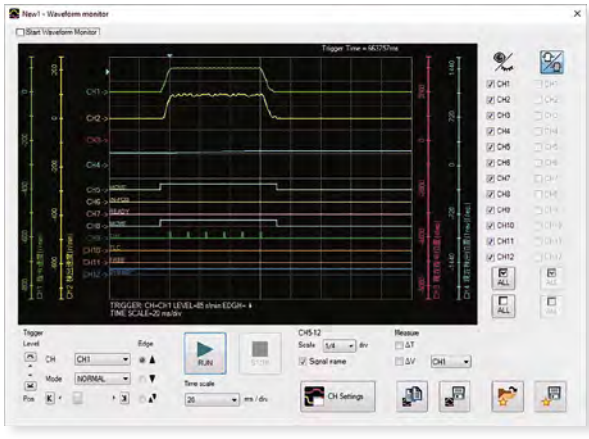

● **Alarm Monitoring**

When Operating

For Maintenance

When an alarm occurs the details of the alarm are recorded as well as the operating status of the motor just before the alarm. Additionally a possible solution is provided which helps with fault finding.

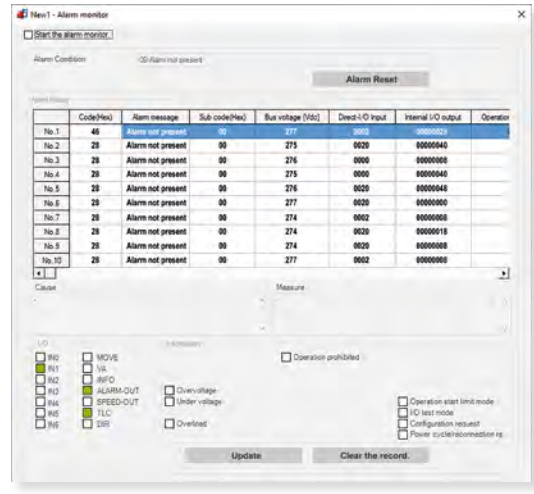

Test Functions

These functions allow for the motor to be operated, controlled and adjusted via Oriental Motors MEXE02 Software. Additionally when directly connected to a PLC or controller the software can monitor the inputs and outputs sent to and from the BLE2 drive. This helps to reduce set-up time.

● **Teaching and Remote Operation**

At Set-up

The "Teaching and Remote Operation" Function allows for the motion variables to be changed and saved during testing, such as speed. Allowing for the machine to be set up before connecting it to the PLC or controller. This helps to reduce set-up time.

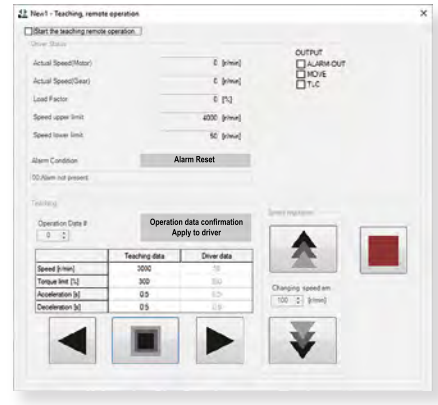

● **I/O Monitor**

At Set-up

When Operating

This function allows us to monitor the digital I/O of the BLE2 driver as well as any external DC voltage. Additionally Inputs & Outputs can be forced. This function is useful for confirming that wiring is correct with the PLC or controller.



Compact, High Power, and High Efficiency Motors

- Uses the New Brushless Motor NexBL.
- Increase in Unit Efficiency by Up to 7% (Compared against the **BLE** Series)

Optimal magnetic design and high-performance materials allow for a stator thickness of only 11.2 mm. It is a high-efficiency power unit that can output 120 W with this thickness.

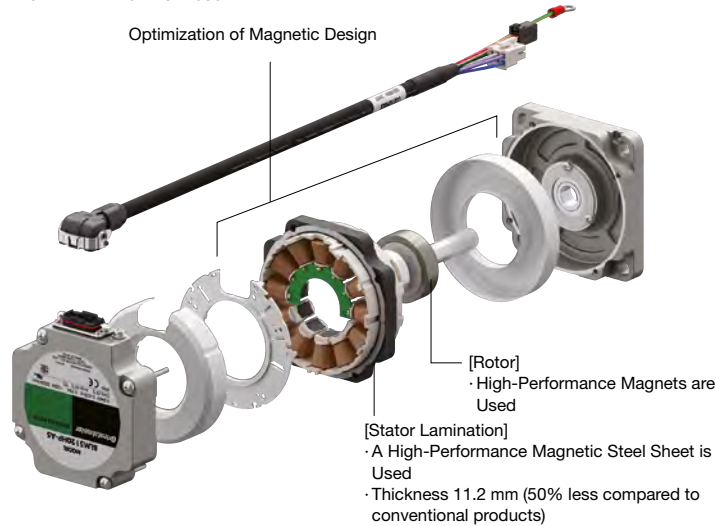





Affordable Prices

Series Name	BLE2 Series	Conventional BLE Series
Motor Weight	1.6 kg	1.9 kg
Motor L Dimensions	45 mm	50 mm
Speed Control Range	16~800 r/min	20~800 r/min
Permissible Torque	0.9 Nm	0.9 Nm

Compared when a combination type motor (output 60 W, gear ratio 5), driver, and 1 m connection cable are used in combination

Product Line

For the **BLE2** series the motor, driver and connection cables are sold separately. They can be purchased in combinations.

Motor	Output Power [W]	Frame Size	Gearhead Gear Ratio (Combination type)	Driver	Power Supply Voltage	Connection Cable
 Combination Type	30	Combination Type 60 mm Round Shaft Type	5, 10, 15, 20, 30, 50, 100, 200		Single-Phase 100-120 VAC Single-Phase 200-240 VAC Three-Phase 200-240 VAC	 Pull-out on output shaft side 0.5, 1, 1.5, 2, 2.5, 3, 4, 5, 7, 10, 15, 20 m
	60	Combination Type 80 mm Round Shaft Type 60 mm				
 Round Shaft Type*	120	Combination Type 90 mm Round Shaft Type				
	200	Combination Type 110 mm Round Shaft Type 90 mm				
	300	Combination Type 90 mm Round Shaft Type				

*For round shaft motors only connection cables facing away from the motors mounting face can be used.
*Round shaft type with flat is available.

For Controlling with Network

- **BLE** Series RS-485 Communication Type

In addition to I/O control, FA network control is now possible using Modbus (RTU) or other network converters.



RS-485 Communication Type

System Configuration

● Motors, drivers and connection cables are sold separately.

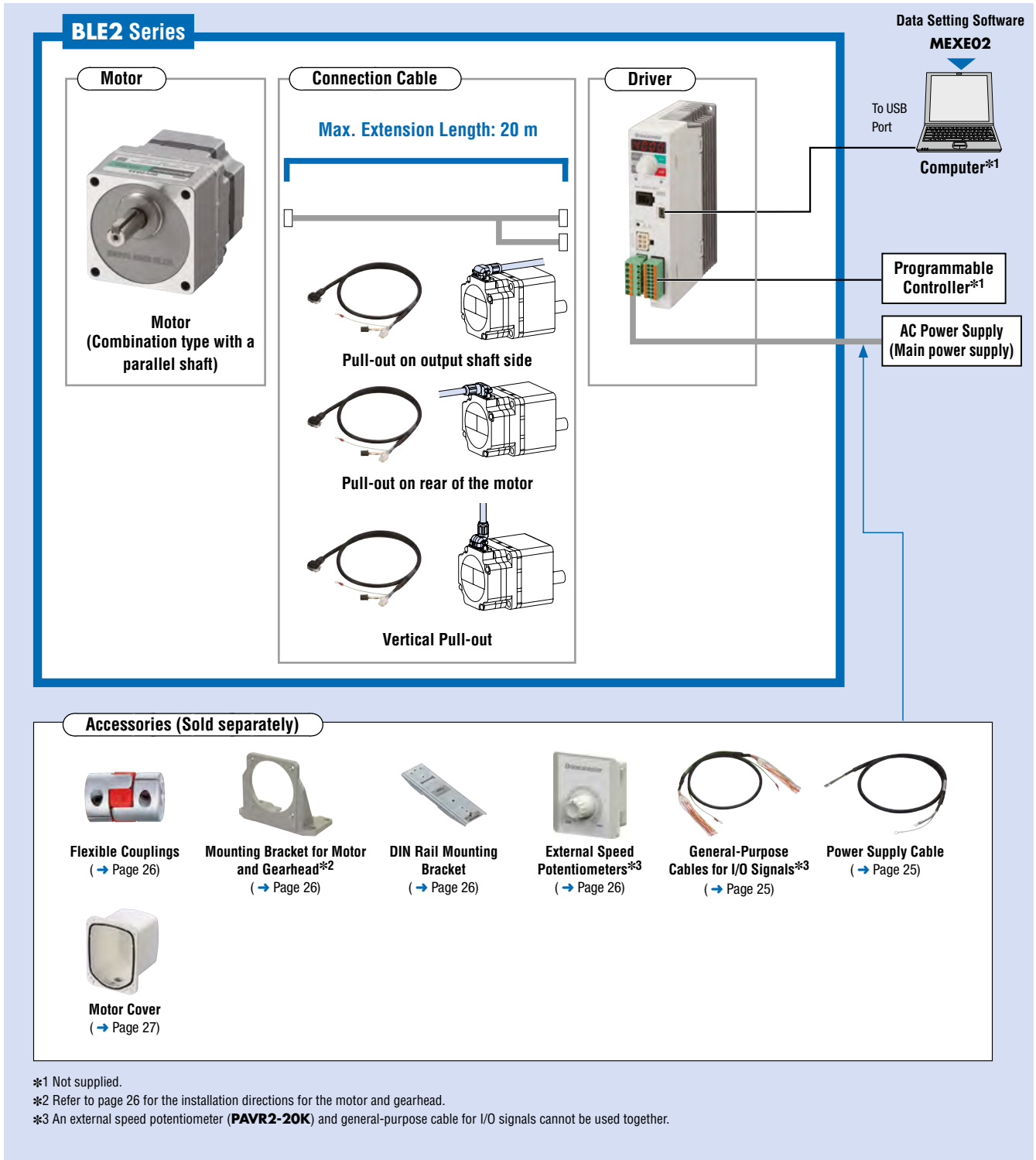

Product Number

● Motor (Combination Type/Round Shaft Type)

BLM 4 60 S H P - 50 S

① ② ③ ④ ⑤ ⑥ ⑦ ⑧

● Drivers

BLE2D 60 - C

① ② ③

● Connection Cable

CC 010 KH BL F

① ② ③ ④ ⑤

Product Line

Please purchase a motor, a driver, and a connection cable.

● Combination Type with a Parallel Shaft Gearhead

Combination Type	Motor and gearhead are delivered pre-assembled.
	The combination of motors and gearheads can be changed, and they are also available separately. In addition, the gearhead can be removed and the assembly position can be changed in 90° increments.

①	Motor Type	BLM: Brushless motor
②	Frame Size	2: 60 mm 4: 80 mm 5: 90 mm 6: 104 mm (Gearhead is 110 mm)
③	Output Power	30: 30 W 60: 60 W 120: 120 W 200: 200 W 300: 300 W
④	Identification Number	S
⑤	Motor Connection Method	H: Connector type
⑥	Degree of Motor Protection	P: IP66 rating
⑦	Gear Ratio and Motor Shaft Type	Number: Gear ratio for combination types A: Round shaft type AC: Round shaft type (with shaft flat)
⑧	Output Shaft Material	S: Stainless steel

①	Driver Type	BLE2D: BLE2 Series driver
②	Output Power	30: 30 W 60: 60 W 120: 120 W 200: 200 W 300: 300 W
③	Power Supply Voltage	A: Single-phase 100-120 VAC C: Single-phase, three-phase 200-240 VAC*

①	Cable Type	CC: Connection cable
②	Length	005: 0.5 m 010: 1 m 015: 1.5 m 020: 2 m 025: 2.5 m 030: 3 m 040: 4 m 050: 5 m 070: 7 m 100: 10 m 150: 15 m 200: 20 m
③	Motor Connection Method	KH: Metal connector type
④	Applicable Model	BL: Brushless motors
⑤	Cable Pull-out Direction	F: Pull-out on output shaft side B: Pull-out on rear of the motor V: Vertical direction

*WARNING: Connecting the BLE2 to three-phase 400 VAC will damage the product.



Motor

Output Power [W]	Product Name	Gear Ratio	List Price
30	BLM230HP-□S	5, 10, 15, 20	183.00 €
		30, 50, 100	189.00 €
		200	197.00 €
60	BLM460SHP-□S	5, 10, 15, 20	202.00 €
		30, 50, 100	208.00 €
		200	217.00 €
120	BLM5120HP-□S	5, 10, 15, 20	255.00 €
		30, 50, 100	263.00 €
		200	271.00 €
200	BLM6200SHP-□S	5, 10, 15, 20	308.00 €
		30, 50	320.00 €
		100, 200	333.00 €
300	BLM6300SHP-□S	5, 10, 15, 20	345.00 €
		30, 50	357.00 €
		100	370.00 €

The following items are included with each product.
Motor, Gearhead, Installation Screws, Parallel Key, Operating Manual

● A number indicating the gear ratio is specified where the box □ is located in the product name.



Connection Cables

Length [m]	Product Name	Price	Length [m]	Product Name	Price
0.5	CC005KHBL ■	29.00 €	4	CC040KHBL ■	54.00 €
1	CC010KHBL ■	29.00 €	5	CC050KHBL ■	62.00 €
1.5	CC015KHBL ■	33.00 €	7	CC070KHBL ■	77.00 €
2	CC020KHBL ■	36.00 €	10	CC100KHBL ■	97.00 €
2.5	CC025KHBL ■	43.00 €	15	CC150KHBL ■	135.00 €
3	CC030KHBL ■	51.00 €	20	CC200KHBL ■	171.00 €

● An **F**, **B** or **V** indicating the cable pull-out direction is specified where the box ■ is located in the product name.

Driver

Output Power [W]	Power Supply Voltage	Product Name	List Price
30	Single-Phase 100-120 VAC	BLE2D30-A	184.00 €
	Single-Phase, Three-Phase 200-240 VAC	BLE2D30-C	184.00 €
60	Single-Phase 100-120 VAC	BLE2D60-A	184.00 €
	Single-Phase, Three-Phase 200-240 VAC	BLE2D60-C	184.00 €
120	Single-Phase 100-120 VAC	BLE2D120-A	188.00 €
	Single-Phase, Three-Phase 200-240 VAC	BLE2D120-C	188.00 €
200	Single-Phase, Three-Phase 200-240 VAC	BLE2D200-C	210.00 €
	Single-Phase, Three-Phase 200-240 VAC	BLE2D300-C	240.00 €

The following items are included with each product.
Driver, Operating Manual, Start-up Guide

2 types of connection cables with different cable pull-out direction are available.

F: Pull-out on output shaft side

B: Pull-out on rear of the motor

V: Vertical Pull-out

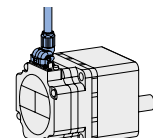
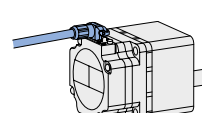
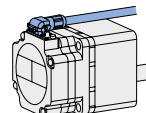

● Round Shaft Type



◇ Motors

Output Power [W]	Product Name	List Price
30	BLM230HP-AS	197.00 €
60	BLM260HP-AS	114.00 €
120	BLM5120HP-AS	137.00 €
200	BLM5200HP-AS	163.00 €
300	BLM5300HP-AS	200.00 €

The following items are included with each product.
Motor, Operating Manual



◇ Drivers

Output Power [W]	Power Supply Voltage	Product Name	List Price
30	Single-Phase 100-120 VAC	BLE2D30-A	184.00 €
	Single-Phase, Three-Phase 200-240 VAC	BLE2D30-C	184.00 €
60	Single-Phase 100-120 VAC	BLE2D60-A	184.00 €
	Single-Phase, Three-Phase 200-240 VAC	BLE2D60-C	184.00 €
120	Single-Phase 100-120 VAC	BLE2D120-A	188.00 €
	Single-Phase, Three-Phase 200-240 VAC	BLE2D120-C	188.00 €
200	Single-Phase, Three-Phase 200-240 VAC	BLE2D200-C	210.00 €
300	Single-Phase, Three-Phase 200-240 VAC	BLE2D300-C	240.00 €

The following items are included with each product.
Driver, Operating Manual, Start-up Guide

◇ Connection Cables

Length [m]	Product Name	List Price
0.5	CC005KHBLB	29.00 €
1	CC010KHBLB	29.00 €
1.5	CC015KHBLB	33.00 €
2	CC020KHBLB	36.00 €
2.5	CC025KHBLB	43.00 €
3	CC030KHBLB	51.00 €

Length [m]	Product Name	List Price
4	CC040KHBLB	54.00 €
5	CC050KHBLB	62.00 €
7	CC070KHBLB	77.00 €
10	CC100KHBLB	97.00 €
15	CC150KHBLB	135.00 €
20	CC200KHBLB	171.00 €



Note

- The only cable pull-out direction of the round shaft type is the rear of the motor.

● Other Product Lineup

Round Shaft Type
Shaft Flat on Output Shaft

- For detailed information on products with shaft flat, please see the Oriental Motor website.

B: Pull-out on rear of the motor

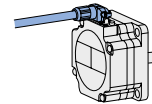

■ Specifications

● 30 W



Product Name	Motor	Combination Type with a Parallel Shaft Gearhead	BLM230HP-□S	
	Driver	Round Shaft Type	BLE2D30-A	BLE2D30-C
Rated Output Power (Continuous)	W		30	
Rated Voltage	VAC		Single-Phase 100-120	Single-Phase 200-240/Three-Phase 200-240
Permissible Voltage Range			-15~+10 %	
Power Frequency	Hz		50/60	
Supply Input Permissible Frequency Range			±5 %	
Rated Input Current	A	1.1	Single-Phase: 0.67/Three-Phase: 0.39	
Max. Input Current	A	3.3	Single-Phase: 2.2/Three-Phase: 1.2	
Rated Speed	r/min		3000	
Rated Torque	Nm		0.096	
Max. Instantaneous Torque	Nm		0.2	
Rotor Inertia J	×10 ⁻⁴ kgm ²		0.042	
Round Shaft Type Permissible Inertia J	×10 ⁻⁴ kgm ²		1.8	
Speed Control Range			80~4000 r/min (Speed ratio 1:50)	
Speed Regulation*	Load	Max. ±0.2 % (±0.5 %): Conditions 0~rated torque, rated speed, rated voltage, normal ambient temperature		
	Voltage	Max. ±0.2 % (±0.5 %): Conditions Rated voltage -15~+10 %, rated speed, no load, normal ambient temperature		
	Temperature	Max. ±0.2 % (±0.5 %): Conditions Operating ambient temperature 0~+50 °C, rated speed, no load, rated voltage		

*The value inside parentheses is the specification for analog setting.

- The values correspond to each specification and characteristics of a stand-alone motor.

- A number indicating the gear ratio is specified where the box □ is located in the product name.

● 60 W



Product Name	Motor	Combination Type with a Parallel Shaft Gearhead	BLM460SHP-□S	
	Driver	Round Shaft Type	BLE2D60-A	BLE2D60-C
Rated Output Power (Continuous)	W		60	
Rated Voltage	VAC		Single-Phase 100-120	Single-Phase 200-240/Three-Phase 200-240
	Permissible Voltage Range		-15~+10 %	
Power Supply Input	Frequency	Hz	50/60	
	Permissible Frequency Range		±5 %	
Rated Input Current	A		1.7	Single-Phase: 1.0/Three-Phase: 0.61
	Max. Input Current	A	5.4	Single-Phase: 3.5/Three-Phase: 2.0
Rated Speed	r/min		3000	
Rated Torque	Nm		0.191	
Max. Instantaneous Torque	Nm		0.4	
Rotor Inertia J	×10 ⁻⁴ kgm ²		0.082	
Round Shaft Type Permissible Inertia J	×10 ⁻⁴ kgm ²		3.75	
Speed Control Range			80~4000 r/min (Speed ratio 1:50)	
Speed Regulation*	Load		Max. ±0.2 % (±0.5 %): Conditions 0~rated torque, rated speed, rated voltage, normal ambient temperature	
	Voltage		Max. ±0.2 % (±0.5 %): Conditions Rated voltage -15~+10 %, rated speed, no load, normal ambient temperature	
	Temperature		Max. ±0.2 % (±0.5 %): Conditions Operating ambient temperature 0~+50 °C, rated speed, no load, rated voltage	

● 120 W



Product Name	Motor	Combination Type with a Parallel Shaft Gearhead	BLM5120HP-□S	
	Driver	Round Shaft Type	BLE2D120-A	BLE2D120-C
Rated Output Power (Continuous)	W		120	
Rated Voltage	VAC		Single-Phase 100-120	Single-Phase 200-240/Three-Phase 200-240
	Permissible Voltage Range		-15~+10 %	
Power Supply Input	Frequency	Hz	50/60	
	Permissible Frequency Range		±5 %	
Rated Input Current	A		2.7	Single-Phase: 1.7/Three-Phase: 1.02
	Max. Input Current	A	7.4	Single-Phase: 4.8/Three-Phase: 3.3
Rated Speed	r/min		3000	
Rated Torque	Nm		0.382	
Max. Instantaneous Torque	Nm		0.8	
Rotor Inertia J	×10 ⁻⁴ kgm ²		0.23	
Round Shaft Type Permissible Inertia J	×10 ⁻⁴ kgm ²		5.6	
Speed Control Range			80~4000 r/min (Speed ratio 1:50)	
Speed Regulation*	Load		Max. ±0.2 % (±0.5 %): Conditions 0~rated torque, rated speed, rated voltage, normal ambient temperature	
	Voltage		Max. ±0.2 % (±0.5 %): Conditions Rated voltage -15~+10 %, rated speed, no load, normal ambient temperature	
	Temperature		Max. ±0.2 % (±0.5 %): Conditions Operating ambient temperature 0~+50 °C, rated speed, no load, rated voltage	

● 200 W



Product Name	Motor	Combination Type with a Parallel Shaft Gearhead	BLM6200SHP-□S	
	Driver	Round Shaft Type	BLM5200HP-AS	BLE2D200-C
Rated Output Power (Continuous)	W		200	
Rated Voltage	VAC		Single-Phase 200-240/Three-Phase 200-240	
	Permissible Voltage Range		-15~+10 %	
Power Supply Input	Frequency	Hz	50/60	
	Permissible Frequency Range		±5 %	
Rated Input Current	A		Single Phase: 2.4/Three-Phase: 1.4	
	Max. Input Current	A	Single-Phase: 6.5/Three-Phase: 4.3	
Rated Speed	r/min		3000	
Rated Torque	Nm		0.637	
Max. Instantaneous Torque	Nm		1.15	
Rotor Inertia J	×10 ⁻⁴ kgm ²		0.454	
Round Shaft Type Permissible Inertia J	×10 ⁻⁴ kgm ²		8.75	
Speed Control Range			80~4000 r/min (Speed ratio 1:50)	
Speed Regulation*	Load		Max. ±0.2 % (±0.5 %): Conditions 0~rated torque, rated speed, rated voltage, normal ambient temperature	
	Voltage		Max. ±0.2 % (±0.5 %): Conditions Rated voltage -15~+10 %, rated speed, no load, normal ambient temperature	
	Temperature		Max. ±0.2 % (±0.5 %): Conditions Operating ambient temperature 0~+50 °C, rated speed, no load, rated voltage	

*The value inside parentheses is the specification for analog setting.

● The values correspond to each specification and characteristics of a stand-alone motor.

● A number indicating the gear ratio is specified where the box □ is located in the product name.

Product Name	Motor	Combination Type with a Parallel Shaft Gearhead	BLM6300SHP-□S
	Driver	Round Shaft Type	BLM5300HP-AS BLE2D300-C
Rated Output Power (Continuous)	W		300
Rated Voltage	VAC		Single-Phase 200-240/Three-Phase 200-240
Permissible Voltage Range			-15~+10%
Power Supply Input	Frequency	Hz	50/60
Permissible Frequency Range			±5%
Rated Input Current	A		Single-Phase: 3.2/Three-Phase: 1.8
Max. Input Current	A		Single-Phase: 8.5/Three-Phase: 6.0
Rated Speed	r/min		3000
Rated Torque	Nm		0.955
Max. Instantaneous Torque	Nm		1.72
Rotor Inertia J	$\times 10^{-4}$ kgm ²		0.67
Round Shaft Type Permissible Inertia J	$\times 10^{-4}$ kgm ²		12
Speed Control Range			80~4000 r/min (Speed ratio 1:50)
Speed Regulation*	Load		Max. ±0.2% (±0.5%): Conditions 0~rated torque, rated speed, rated voltage, normal ambient temperature
	Voltage		Max. ±0.2% (±0.5%): Conditions Rated voltage -15~+10%, rated speed, no load, normal ambient temperature
	Temperature		Max. ±0.2% (±0.5%): Conditions Operating ambient temperature 0~+50°C, rated speed, no load, rated voltage

- *The value inside parentheses is the specification for analog setting.
- The values correspond to each specification and characteristics of a stand-alone motor.
- A number indicating the gear ratio is specified where the box □ is located in the product name.

Speed – Torque Characteristics

Continuous Duty Region: Continuous operation is possible in this region.
 Limited Duty Region: This region is used primarily when accelerating.

● 30 W

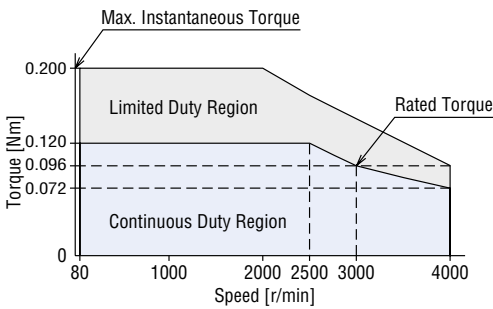

● 60 W

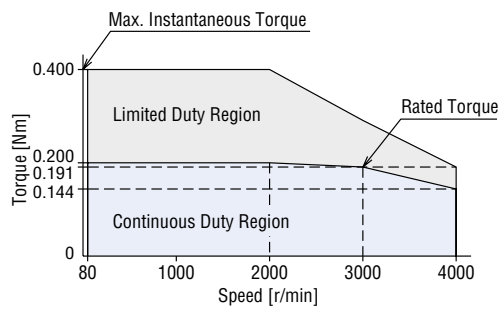

● 120 W

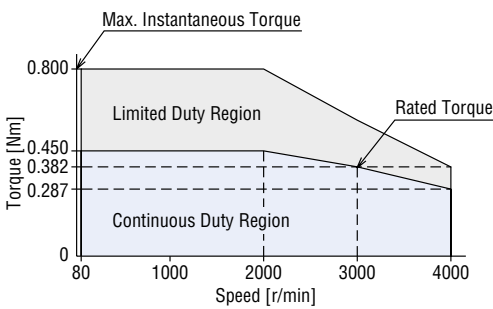

● 200 W

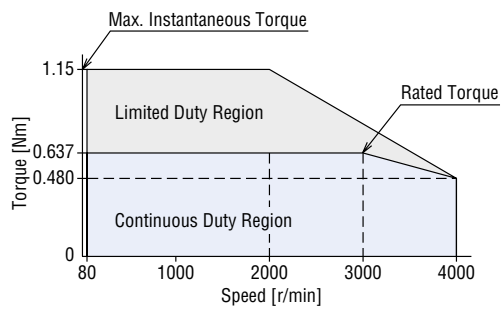

● 300 W

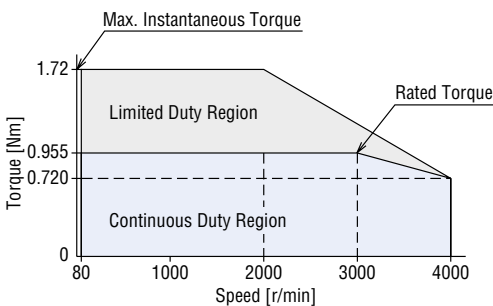

- The values correspond to each specification and characteristics of a stand-alone motor. The speed – torque characteristics show the values when rated voltage is applied.

Common Specifications

Item	Specifications
Speed Setting Methods	Digital Setting ·Control Panel ·Data Setting Software MEXE02
	Analog Setting ·Set using an External Speed Potentiometer PAVR2-20K (Sold separately): 0~20 kΩ, 0.05 W min. ·Set using External DC Voltage: 0~10 VDC, 1 mA min. (Factory setting: 0~5 VDC)
Acceleration/ Deceleration Time	Setting Range 0.0~15.0 s (Factory setting: 0.5 s)
	Setting Method ·Control Panel ·Data Setting Software MEXE02
Torque Limiting*1	Setting Range 0~300% (Factory setting: 300 %)
	Digital Setting ·Control Panel ·Data Setting Software MEXE02
	Analog Setting ·Set with an External Speed Potentiometer PAVR2-20K (Sold separately): 0~20 kΩ, 0.05 W min. ·Set using External DC Voltage: 0~10 VDC, 1 mA min. (Factory setting: 0~5 VDC)
Operating Data Setting Number	Max. 16 points (Factory setting: 4 points)
Input Signals	Photocoupler Input Input Resistance: 6.6 kΩ Connectable External DC Power Supply: 24 VDC -15~ +20 % Current 100 mA or more. Sink Input/Source Input Supports External Wiring
	Arbitrary signal assignment to IN0~IN6 input (7 points) is possible []: Initial Setting [FWD], [REV], [STOP-MODE], [M0], [M1], [ALARM-RESET], M2, M3, H-FREE, TL, HMI, EXT-ERROR START/STOP*2, RUN/BRAKE*2, CW/CCW*2
Output Signal	Photocoupler and Open-Collector Output (ON Power supply: 1.6 V max.) External Power Supply: 4.5~30 VDC 100 mA max. (5 mA min. for SPEED-OUT output power) Sink Output/Source Output Supported through external wiring
	Arbitrary signal assignment to OUT0, OUT1 (2 points) is possible. []: Initial setting [SPEED-OUT], [ALARM-OUT], MOVE, INFO, TLC, VA, DIR
Protective Function	When the following protective functions are activated, the output from ALARM-OUT will turn OFF and the motor will perform a coasting stop. At the same time, the alarm code will be displayed and the ALARM LED will blink. Overcurrent, main circuit overheat, overvoltage, undervoltage, sensor error, main circuit output error, overload, over-speed, EEPROM error, initial sensor error, initial operation prohibited, external stop
General Information	When general information is generated, the INFO output will turn ON. The motor will continue to operate. Overvoltage, undervoltage, overload, operation start restriction mode, I/O test mode, configuration request, power on request, operation prohibited
Max. Extension Length	Motor and driver distance: 20.5 m [when an accessory connection cable (for relaying) is used]
Time Rating	Continuous

*1 For the torque limit, an error up to a max. of approximately $\pm 10\%$ (at rated torque and rated speed) may occur between the setting value and generated torque due to the setting speed, power supply voltage and motor cable extension length.

*2 Can be used when 3 wire input method is selected.

General Specifications

Item	Motor	Driver
Insulation Resistance	100 MΩ or more when 500 VDC megger is applied between the windings and the case after continuous operation under normal ambient temperature and humidity.	The measured value is 100 MΩ or more when a 500 VDC megger is applied between the power supply terminal and the protective earth terminal and between the power supply terminal and the signal I/O terminal after continuous operation under normal ambient temperature and humidity.
Dielectric Voltage	Sufficient to withstand 1.5 kVAC at 50 Hz applied between the windings and the case for 1 minute after continuous operation under normal ambient temperature and humidity.	Sufficient to withstand the application of 1.5 kVAC at 50 Hz between the power supply terminal and the protective earth terminal for 1 minute, and with application of 1.5 kVAC at 50 Hz between the power supply terminal and the signal I/O terminal for 1 minute after continuous operation under normal ambient temperature and humidity.
Temperature Rise	The temperature rise of the windings is 50 °C max. and that of the case surface is 40 °C max.*1, measured by the thermocouple method after rated continuous operation under normal ambient temperature and humidity.	The temperature rise of the heat sink is 50 °C max., measured by the thermocouple method after rated continuous operation under normal ambient temperature and humidity.
Operating Environment*2	Ambient Temperature	0 ~ +40 °C (Non-freezing)
	Ambient Humidity	85 % max. (Non-condensing)
	Altitude	Max. of 1000 m above sea level
	Atmosphere	No corrosive gases or dust. No oil splashing. Cannot be used in a radioactive area, magnetic field, vacuum, or other special environments.
	Vibration	Not subject to continuous vibration or excessive shock. Conforms to IEC 60068-2-6, "Sine-wave vibration test method" Frequency Range: 10~55 Hz, Half Amplitude: 0.15 mm Sweep Direction: 3 directions (X, Y, Z) Number of Sweeps: 20 times
Storage Conditions*4	Ambient Temperature	-20 ~ +70 °C (Non-freezing)
	Ambient Humidity	85 % max. (Non-condensing)
	Altitude	Max. of 3000 m above sea level
	Atmosphere	No corrosive gases or dust. No oil splashing. Cannot be used in a radioactive area, magnetic field, vacuum, or other special environments.
Heat-Resistant Class	EN Standard: 120 (E)	—
Degree of Protection*5	When connected to a cable: IP66 (Excluding the installation surface of the round shaft type and connectors on the driver side)	IP20

*1 For round shaft types, install on a heat sink (material: aluminum) of one of the following sizes to maintain a motor case surface temperature of 90°C or less.

- 30 W type: 115×115 mm thickness 5 mm, 60 W type: 135×135 mm thickness 5 mm
- 120 W type: 165×165 mm thickness 5 mm, 200 W type: 200×200 mm thickness 5 mm
- 300 W type: 250×250 mm thickness 6 mm

*2 Install the driver to a location that has the same heat radiation capability as an aluminum metal plate.

- Installation of a stand-alone driver 200×200 mm thickness 2 mm
- Installation of multiple drivers 350×350 mm thickness 2 mm

*3 0 ~ +40 °C for installation of multiple drivers.

*4 The storage condition applies to short periods such as the period during transport.

*5 The IP display indicating watertight and dust-resistant performance is regulated by IEC 60529 and IEC 60034-5.

Note

- Do not measure insulation resistance or perform a dielectric strength test while the motor and driver are connected.

● Motor Material and Surface Treatment

- Materials Case: Aluminum
Output Shaft: Stainless steel
Screws: Stainless steel (externally facing screws only; protective earth terminals excluded)
- Surface treatment Case: Paint (installation surface excluded)

■ Permissible Torque of Combination Types

● Combination Type with a Parallel Shaft Gearhead

Unit: [Nm]

Output Power [W]	Gear Ratio								
	Motor Shaft Speed	5	10	15	20	30	50	100	200
30	80~2500 r/min	0.54	1.1	1.6	2.2	3.1	5.2	6	6
	3000 r/min	0.43	0.86	1.3	1.7	2.5	4.1	6	6
	4000 r/min	0.32	0.65	0.97	1.3	1.9	3.1	5.4	5.4
60	80~2000 r/min	0.9	1.8	2.7	3.6	5.2	8.6	16	16
	3000 r/min	0.86	1.7	2.6	3.4	4.9	8.2	16	16
	4000 r/min	0.65	1.3	1.9	2.6	3.7	6.2	12.4	14
120	80~2000 r/min	2	4.1	6.1	8.1	11.6	19.4	30	30
	3000 r/min	1.7	3.4	5.2	6.9	9.9	16.4	30	30
	4000 r/min	1.3	2.6	3.9	5.2	7.4	12.3	24.7	27
200	80~3000 r/min	2.9	5.7	8.6	11.5	16.4	27.4	51.6	70
	4000 r/min	2.2	4.3	6.5	8.6	12.4	20.6	38.9	63
300	80~3000 r/min	4.3	8.6	12.9	17.2	24.6	41.1	70	-
	4000 r/min	3.2	6.4	9.7	12.9	18.5	30.8	58	-

● A colored background indicates gear shaft rotation in the same direction as the motor shaft. Others rotate in the opposite direction.

■ Output Shaft Speed of Combination Types

Unit: [r/min]

Motor Shaft Speed	Gear Ratio							
	5	10	15	20	30	50	100	200
80 r/min	16	8	5.3	4	2.7	1.6	0.8	0.4
2000 r/min	400	200	133	100	66.7	40	20	10
2500 r/min	500	250	167	125	83.3	50	25	12.5
3000 r/min	600	300	200	150	100	60	30	15
4000 r/min	800	400	267	200	133	80	40	20

■ Permissible Inertia J of Combination Types

● Combination Type with a Parallel Shaft Gearhead

Unit: $\times 10^{-4}$ kgm²

Output Power [W]	Gear Ratio								
	5	10	15	20	30	50	100	200	
30		12	50	110	200	370	920	2500	5000
	When instantaneous stop or instantaneous bi-directional operation is performed*	1.55	6.2	14	24.8	55.8	155	155	155
60		22	95	220	350	800	2200	6200	12000
	When instantaneous stop or instantaneous bi-directional operation is performed*	5.5	22	49.5	88	198	550	550	550
120		45	190	420	700	1600	4500	12000	25000
	When instantaneous stop or instantaneous bi-directional operation is performed*	25	100	225	400	900	2500	2500	2500
200		100	460	1000	1700	3900	9300	18000	37000
	When instantaneous stop or instantaneous bi-directional operation is performed*	50	200	450	800	1800	5000	5000	5000
300		100	460	1000	1700	3900	9300	18000	-
	When instantaneous stop or instantaneous bi-directional operation is performed*	50	200	450	800	1800	5000	5000	-

*It is also applicable when digitally setting the deceleration time to below 0.1 seconds.

■ Permissible Radial Load and Permissible Axial Load

● Combination Type with a Parallel Shaft Gearhead

Output Power [W]	Gear Ratio		Permissible Radial Load		Permissible Axial Load [N]
			10 mm from the end of the output shaft [N]	20 mm from the end of the output shaft [N]	
30	5	80~3000 r/min	100	150	40
		4000 r/min	90	110	
	10, 15, 20	80~3000 r/min	150	200	
		4000 r/min	130	170	
	30, 50, 100, 200	80~3000 r/min	200	300	
		4000 r/min	180	230	
60	5	80~3000 r/min	200	250	100
		4000 r/min	180	220	
	10, 15, 20	80~3000 r/min	300	350	
		4000 r/min	270	330	
	30, 50, 100, 200	80~3000 r/min	450	550	
		4000 r/min	420	500	
120	5	80~3000 r/min	300	400	150
		4000 r/min	230	300	
	10, 15, 20	80~3000 r/min	400	500	
		4000 r/min	370	430	
	30, 50, 100, 200	80~3000 r/min	500	650	
		4000 r/min	450	550	
200	5, 10, 15, 20	80~3000 r/min	550	800	200
		4000 r/min	500	700	
	30, 50	80~3000 r/min	1000	1250	300
		4000 r/min	900	1100	
	100, 200	80~3000 r/min	1400	1700	400
		4000 r/min	1200	1400	
300	5, 10, 15, 20	80~3000 r/min	550	800	200
		4000 r/min	500	700	
	30, 50	80~3000 r/min	1000	1250	300
		4000 r/min	900	1100	
	100	80~3000 r/min	1400	1700	400
		4000 r/min	1200	1400	

● Round Shaft Type

Output [W]	Permissible Radial Load		Permissible Axial Load
	10 mm from the end of the output shaft [N]	20 mm from the end of the output shaft [N]	
30	80	100	Half of motor mass max.
60	80	100	
120	150	170	
200	150	170	
300	150	170	

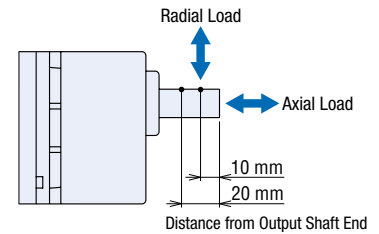

■ Dimensions (Unit = mm)

● The motor dimensions in this catalogue are the dimensions when a separately sold connection cable (the color in the diagrams) is attached.

Listed masses do not include the mass of the connection cable.

● Refer to page 20 for the dimensions and masses of connection cables.

● "Installation screws" are included with the combination type. Dimensions for installation screws → Page 20

● A number indicating the gear ratio is specified where the box □ is located in the product name.

● Motor: 30 W

◇ Combination Type with a Parallel Shaft Gearhead

Product Name	Motor Product Name	Gearhead Product Name	Gear Ratio	L	Mass [kg]
BLM230HP-□S	BLM230HP-GFV	GFV2G□S	5~20	34	0.85
			30~100	38	
			200	43	

● When connection cable is attached for pull-out on output shaft side

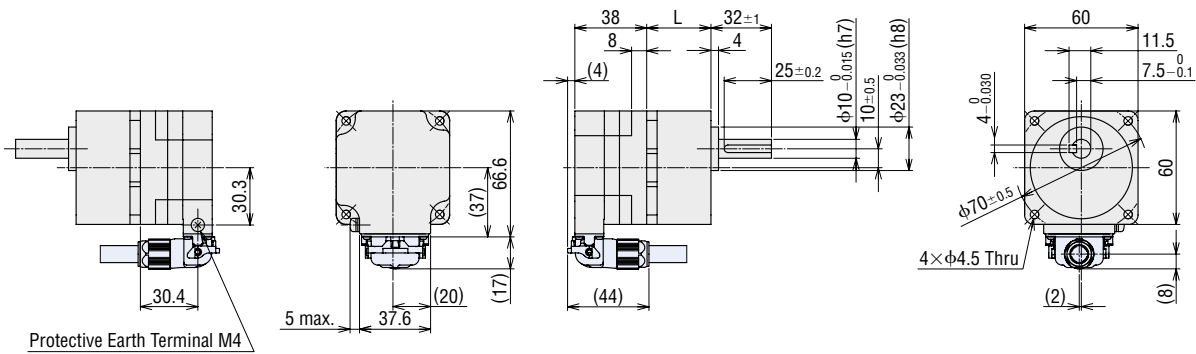

● At the time of shipment, a key is fixed in the key slot of the gearhead shaft.

● When connection cable is attached for pull-out on rear of the motor

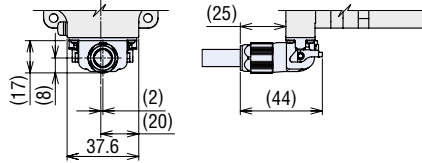

● For vertical pull-out

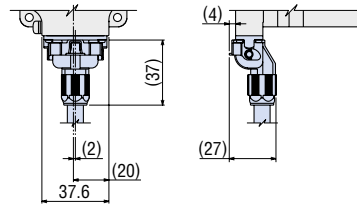

◇ Round Shaft Type

BLM230HP-A5

Mass: 0.35 kg

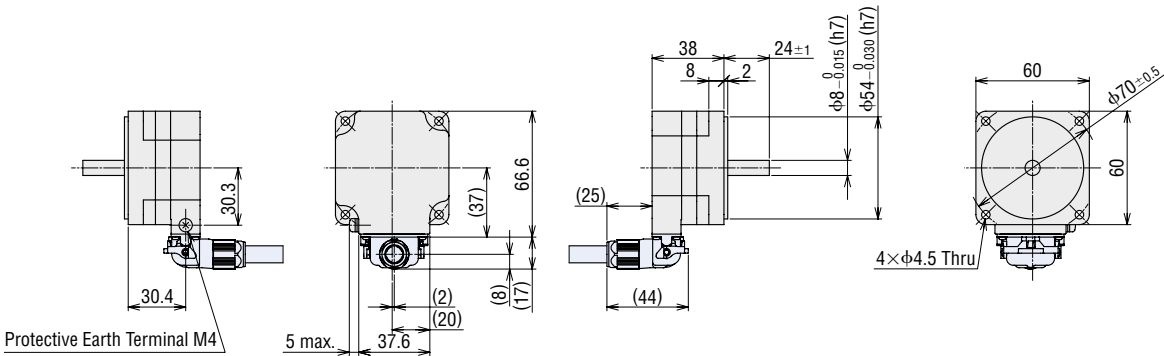

● Motor: 60 W

◇ Combination Type with a Parallel Shaft Gearhead

Product Name	Motor Product Name	Gearhead Product Name	Gear Ratio	L	Mass [kg]
BLM460SHP-□S	BLM460SHP-GFV	GFV4G□S	5~20	41	1.6
			30~100	46	
			200	51	

● When connection cable is attached for pull-out on output shaft side

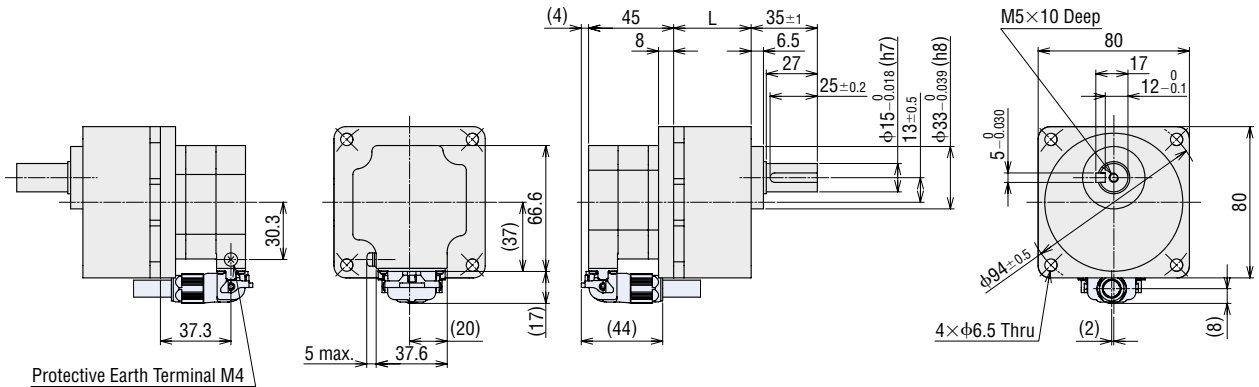

● At the time of shipment, a key is fixed in the key slot of the gearhead shaft.

● When connection cable is attached for pull-out on rear of the motor

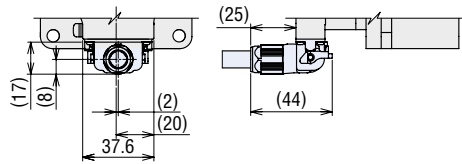

● For vertical pull-out

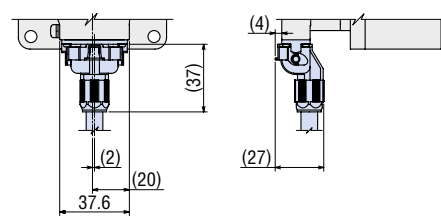

◇ Round Shaft Type

BLM260HP-AS

Mass: 0.52 kg

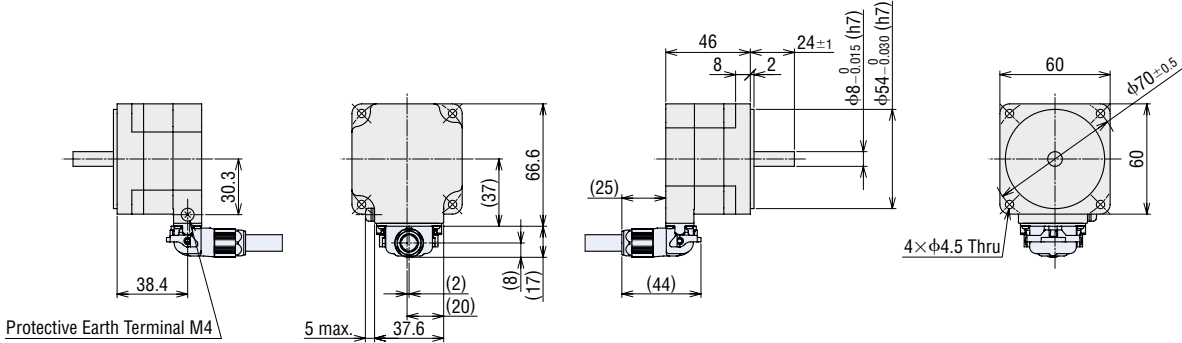

● Motor: 120W

◇ Combination Type with a Parallel Shaft Gearhead

Product Name	Motor Product Name	Gearhead Product Name	Gear Ratio	L	Mass [kg]
BLM5120HP-□S	BLM5120HP-GFV	GFV5G□S	5~20	45	2.6
			30~100	58	
			200	64	

● When connection cable is attached for pull-out on output shaft side

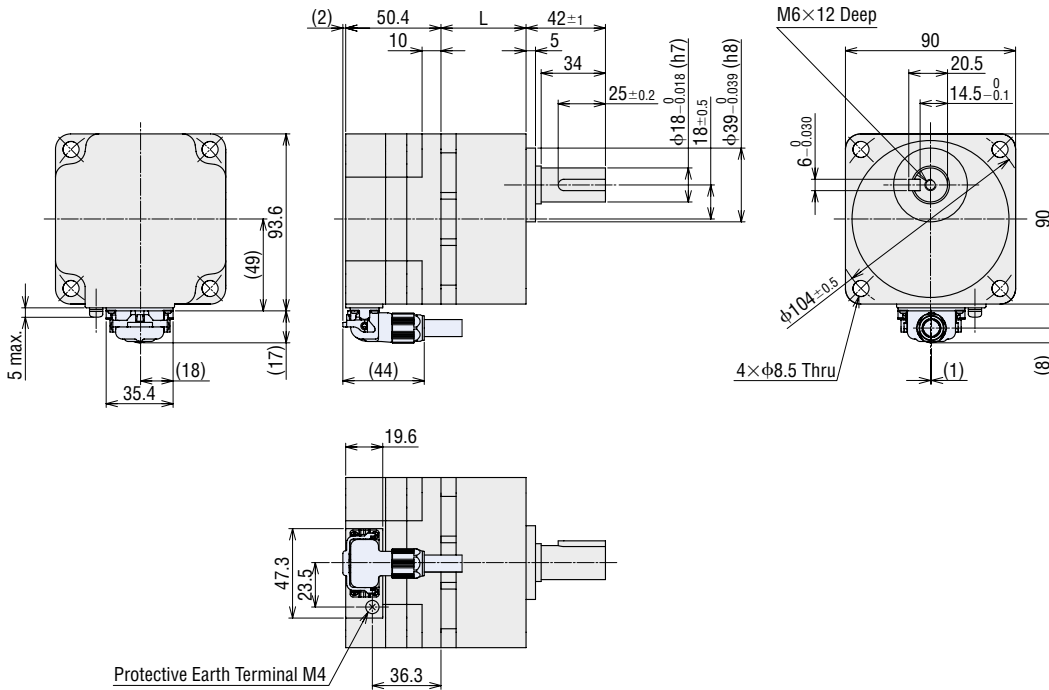

● At the time of shipment, a key is fixed in the key slot of the gearhead shaft.

● When connection cable is attached for pull-out on rear of the motor

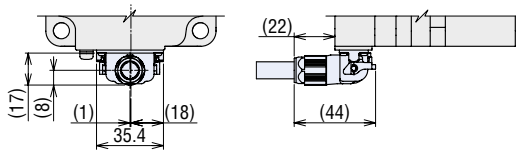

● For vertical pull-out

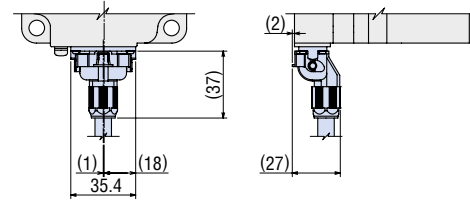

◇ Round Shaft Type

BLM5120HP-AS

Mass: 1.1 kg

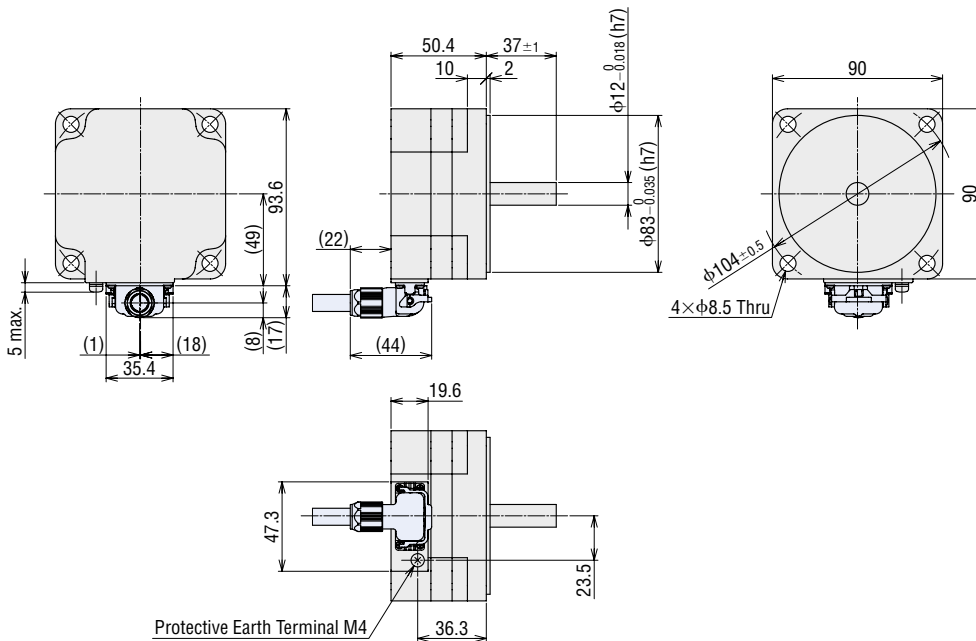

● Motor: 200W

◇ Combination Type with a Parallel Shaft Gearhead

Product Name	Motor Product Name	Gearhead Product Name	Gear Ratio	L	Mass [kg]
BLM6200SHP-□S	BLM6200SHP-GFV	GFV6G□S	5~20	60	4.7
			30, 50	72	
			100, 200	86	

● When connection cable is attached for pull-out on output shaft side

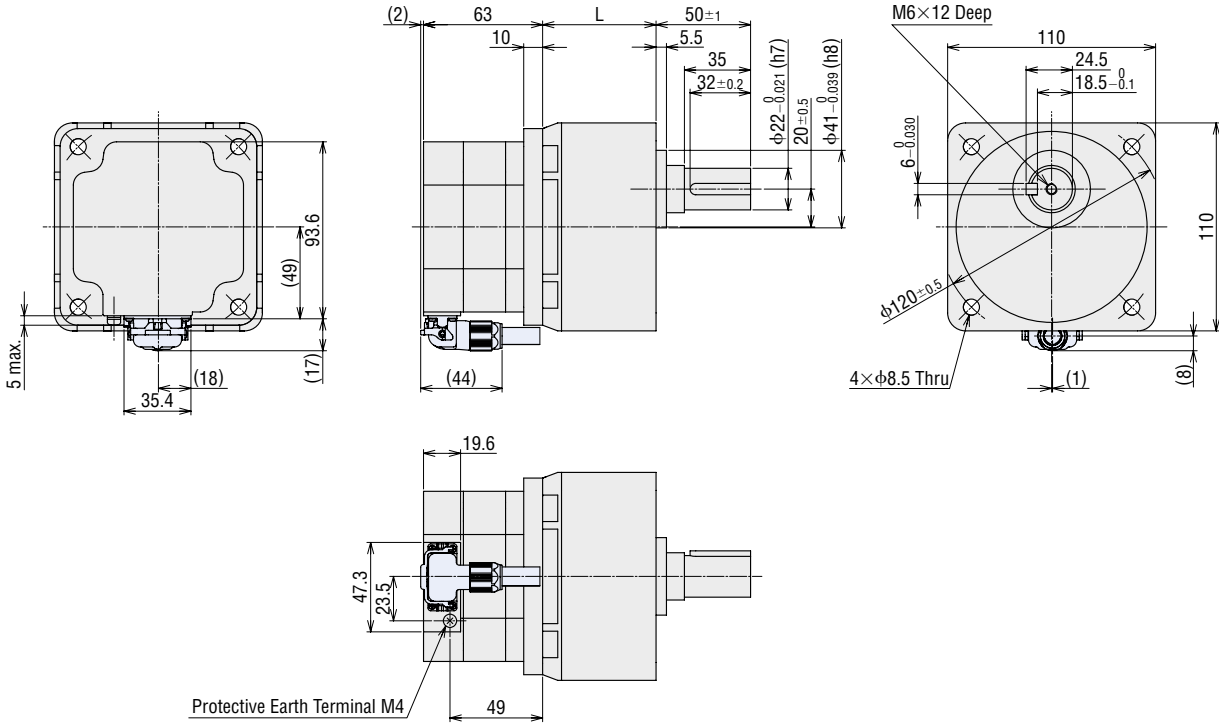

● At the time of shipment, a key is fixed in the key slot of the gearhead shaft.

● When connection cable is attached for pull-out on rear of the motor

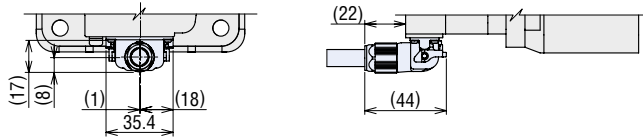

● For vertical pull-out

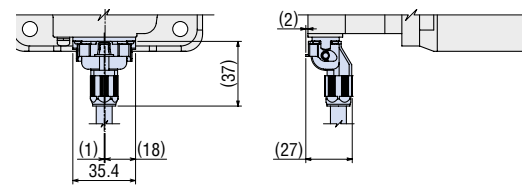

◇ Round Shaft Type

BLM5200HP-AS

Mass: 1.6 kg

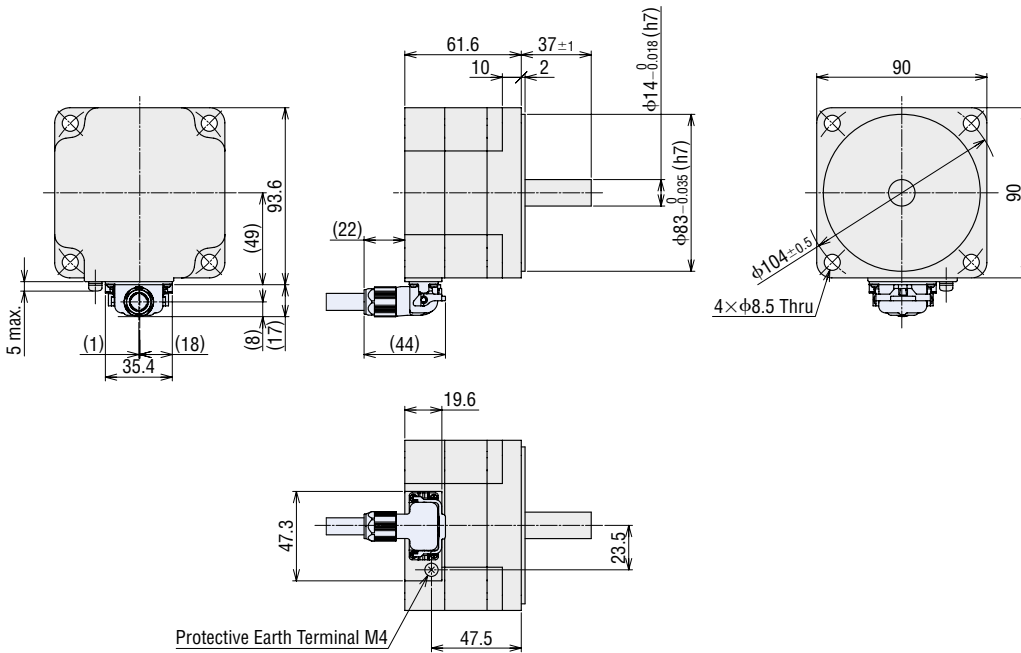

● Motor: 300W

◇ Combination Type with a Parallel Shaft Gearhead

Product Name	Motor Product Name	Gearhead Product Name	Gear Ratio	L	Mass [kg]
BLM6300SHP-□S	BLM6300SHP-GFV	GFV6G□S	5~20	60	5.2
			30, 50	72	
			100	86	

● When connection cable is attached for pull-out on output shaft side

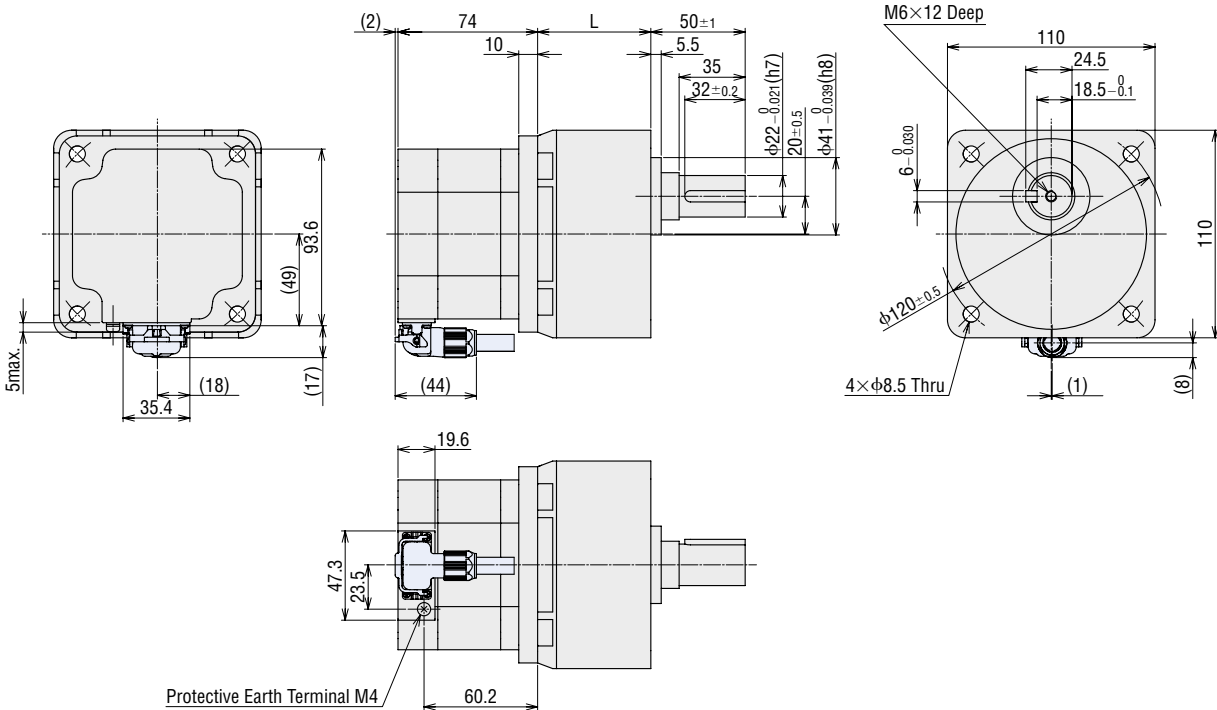

● At the time of shipment, a key is fixed in the key slot of the gearhead shaft.

● When connection cable is attached for pull-out on rear of the motor

● For vertical pull-out

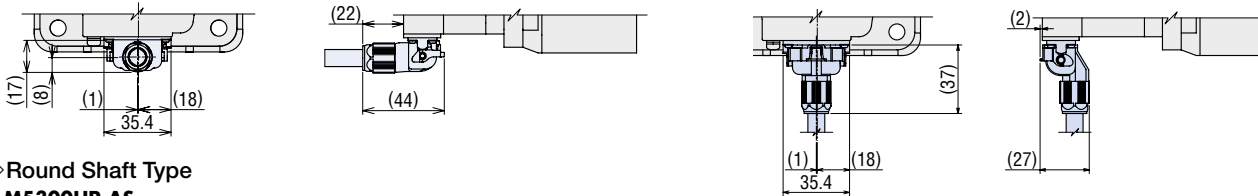

◇ Round Shaft Type

BLM5300HP-AS

Mass: 2.1 kg

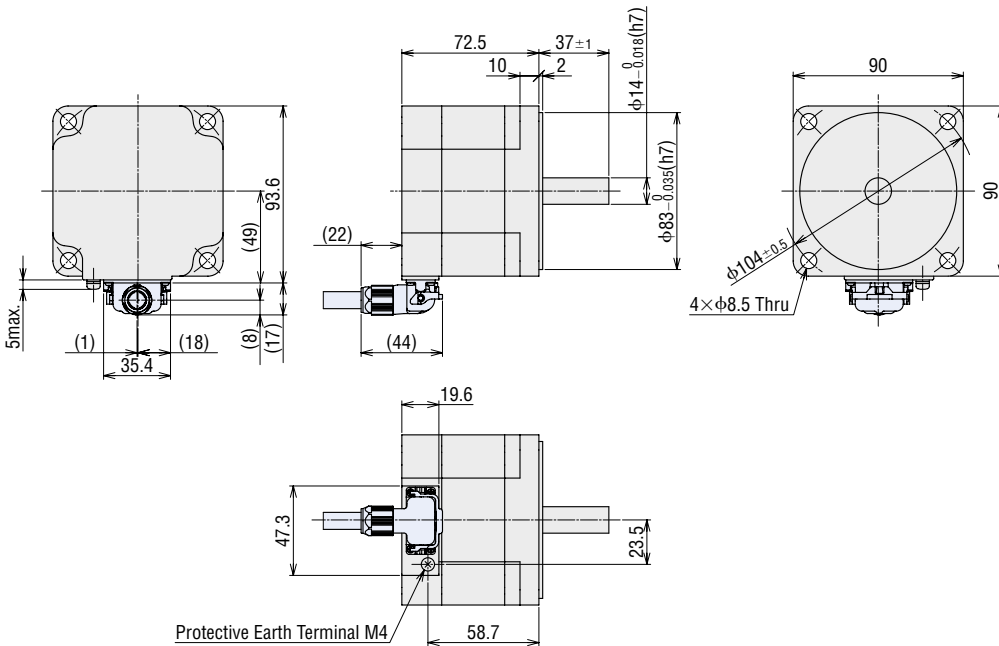

● Driver

BLE2D30-A, BLE2D30-C, BLE2D60-A, BLE2D60-C, BLE2D120-A, BLE2D120-C, BLE2D200-C, BLE2D300-C

Mass: 0.8 kg

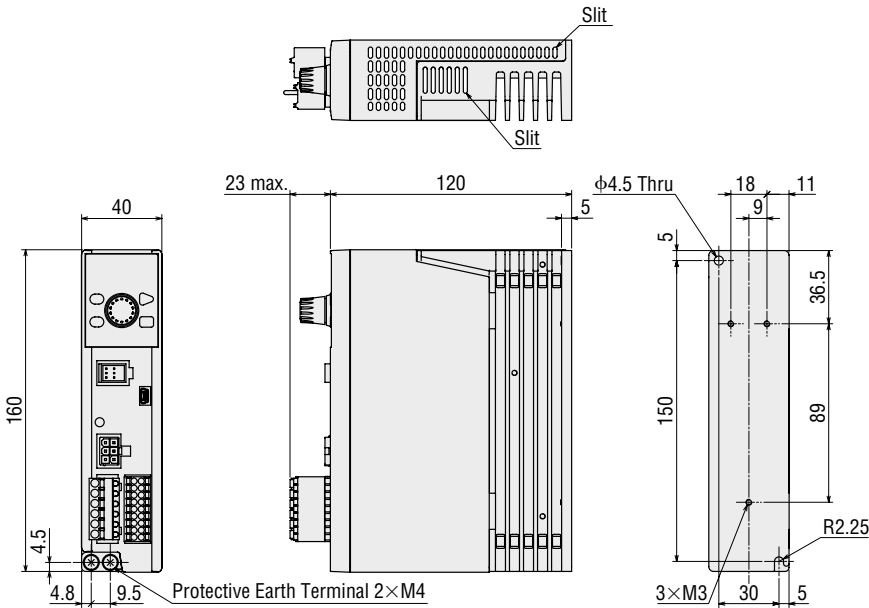

● Connection Cable

Length L [m]	Product Name			Mass [kg]
	Pull-out on output shaft side	Pull-out on rear of the motor	Vertical direction	
0.5	CC005KHBLF	CC005KHBLB	CC005KHBLV	0.08
1	CC010KHBLF	CC010KHBLB	CC010KHBLV	0.12
1.5	CC015KHBLF	CC015KHBLB	CC015KHBLV	0.2
2	CC020KHBLF	CC020KHBLB	CC020KHBLV	0.25
2.5	CC025KHBLF	CC025KHBLB	CC025KHBLV	0.32
3	CC030KHBLF	CC030KHBLB	CC030KHBLV	0.38
4	CC040KHBLF	CC040KHBLB	CC040KHBLV	0.49
5	CC050KHBLF	CC050KHBLB	CC050KHBLV	0.62
7	CC070KHBLF	CC070KHBLB	CC070KHBLV	0.86
10	CC100KHBLF	CC100KHBLB	CC100KHBLV	1.2
15	CC150KHBLF	CC150KHBLB	CC150KHBLV	1.9
20	CC200KHBLF	CC200KHBLB	CC200KHBLV	2.5

- Pull-out on output shaft side, Pul-out on rear of the motor

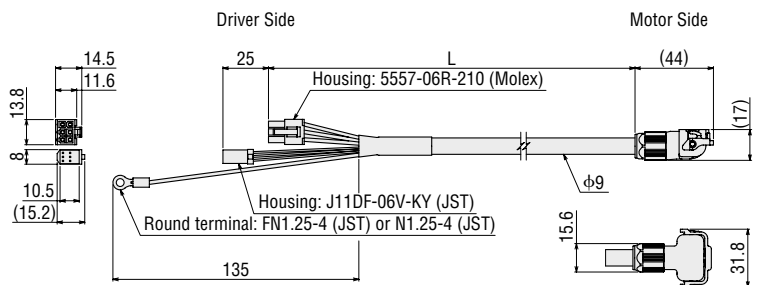

- Vertical pull-out

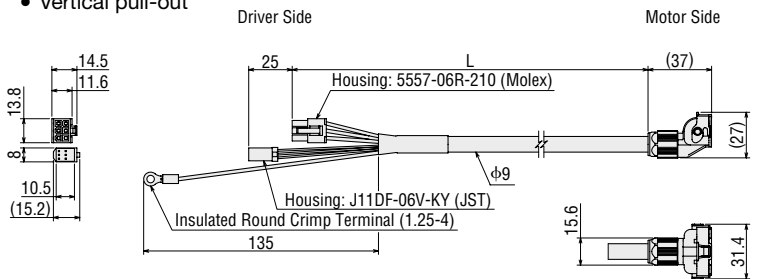

■ Installation Screw Dimensions

Included with a combination type with a parallel shaft gearhead.

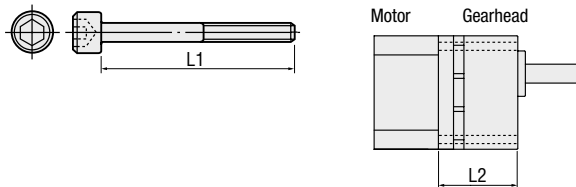

Gearhead Product Name	Installation Screw		L2 [mm]
	L1 [mm]	Screw Size	
GFV2G5~20S	50	M4 P0.7	42
GFV2G30~100S	55		46
GFV2G200S	60		51
GFV4G5~20S	60	M6 P1.0	49
GFV4G30~100S	65		54
GFV4G200S	70		59
GFV5G5~20S	70	M8 P1.25	55
GFV5G30~100S	85		68
GFV5G200S	90		74
GFV6G5~20S	85	M8 P1.25	70
GFV6G30~50S	100		82
GFV6G100S~200S	110		96

- Installation Screws: Plain washer, spring washer included (4 each)
- The installation screw material is stainless steel.

Connection and Operation

Names and Functions of Driver Parts

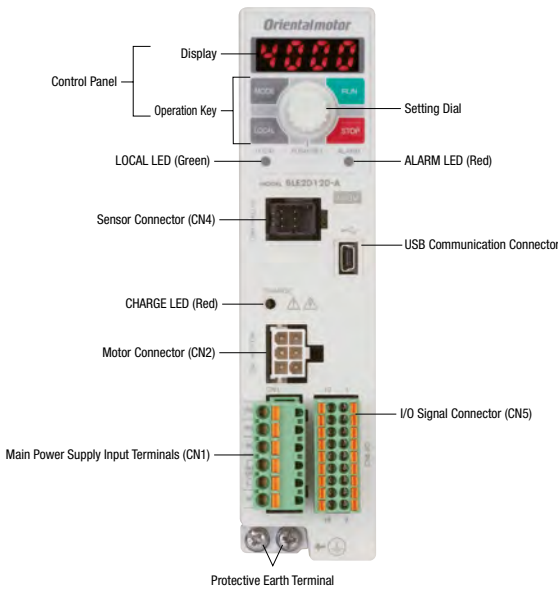

Name	Indication	Description
Control Panel	—	Indicator: Displays monitor contents, setting screen, alarm, etc.
	MODE LOCAL RUN STOP	Operation Key: Switches operation modes and changes parameters Operates and stops the motor using RUN key and STOP key during local control operation
	Setting Dial	Setting Dial: PUSH-SET Sets the speed and parameters
LOCAL LED (Green)	LOCAL	Illuminates during local control operation
ALARM LED (Red)	ALARM	Blinks when an alarm occurs
CHARGE LED (Red)	CHARGE	Illuminates when the main power supply is turned on Turns off after the main power supply is turned off and internal residual voltage is reduced to a stable level
Main Power Supply Input Terminals (CN1)	—	Connects the main power supply
	L, N, NC	Single-Phase 100-120 VAC: Connects 100-120 VAC to L and N. NC is not used.
	L1, L2, NC	Single-Phase 200-240 VAC: Connects 200-240 VAC to L1 and L2. NC is not used.
	L1, L2, L3	Three-Phase 200-240 VAC: Connects three-phase 200-240 VAC to L1, L2, L3
	RG1, RG2	No connection
Motor Connector (CN2)	MOTOR	Connects a connection cable's power connector (white)
Sensor Connector (CN4)	HALL-S	Connects a connection cable's sensor connector (black)
USB Communication Connector		Connects a PC that has data setting software MEXEO2 installed
I/O Signal Connector (CN5)	—	Connects input signals
	I/O	Connects accessories such as external speed potentiometer (sold separately) and external DC power supply
	—	Connects output signals
Protective Earth Terminal		Connects the protective earth terminal of a connection cable and a grounding conductor

Operation Key

BLE2 Series has 4 operating modes.

Operating Mode	Description	Setting Items
Monitoring Mode	This mode is displayed when the power is turned on.	Speed, load factor, operating data number, alarm, general information, I/O monitor
Data Mode	It sets a max. of 16 speeds of operating data.	Speed, torque limiting value, acceleration time, deceleration time, reset
Parameter Mode	It sets various parameters.	Basic setting parameter, speed and torque limiting adjustment parameter, alarm and general information setting parameter, operation setting parameter, I/O operation parameter, I/O function selection parameter, I/F function parameter, reset, configuration
Test Mode	It is used to check the connection status of the I/O signals.	

Main Power Supply Input Terminals (CN1)

Connects the main power supply. Connect a power supply that matches the power supply voltage to be used.

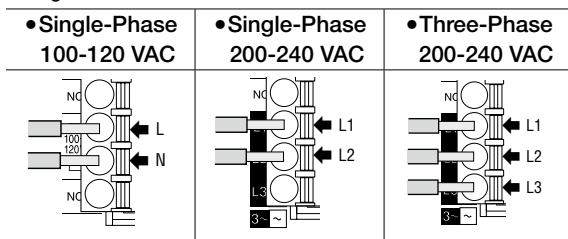

• **Applicable Lead Wire Size**
AWG18~14 (0.75~2.0 mm²)

USB Cable Connection

Please use a USB cable which meets the following specifications.

Specifications	USB 2.0 (Full speed)
Cable	Length: 3 m max. Configuration: A - mini-B

Operation Using the Control Panel

Selection of the Operation Control

Pressing the "LOCAL key" will illuminate the LOCAL LED and the control panel can be used to operate.

Selection of the Rotation Direction

The rotation direction of a motor will change every time the "MODE key" is pressed.

Starting and Stopping a Motor

Motor rotates when "RUN" is pressed.

Motor stops when "STOP" is pressed.

Speed Setting Method

The display will flash when "Setting Dial" is pressed, and the speed increases when it is turned clockwise. Turning it counterclockwise will decelerate. Pressing the "Setting Dial" will set the speed.

Control Panel

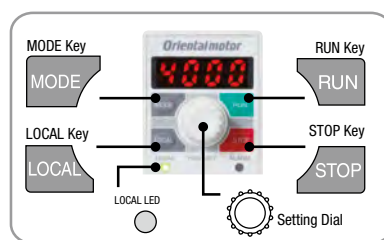

● Operation by External Signals

◇ I/O Signal Connector (CN5)

Pin No.	Signal Type	Signal Name	Function*	Description
1	Input	IN-COM0	IN-COM0	Input signal common (for external power supply)
2		IN0	FWD	The motor rotates when FWD input or REV input is turned ON. Turning it OFF decelerates the motor to a stop.
3		IN1	REV	
4		IN2	STOP-MODE	Selects the method for stopping the motor.
5		IN3	M0	Selects the operation data number through the selection of M0, M1 input ON/OFF.
6		IN4	M1	
7		IN5	ALARM-RESET	Alarms are reset.
8		IN6	Not used	Assigns various functions.
9		IN-COM1	IN-COM1	Input signal common (for internal power supply: 0 V)
10		N.C.	—	No connection.
12	External Analog Setting Input	VH	It is connected when speed and torque limiting value are set externally using an external speed potentiometer or external DC voltage.	
13		VM		
14		VL		
15	Output	OUT0+	SPEED-OUT	30 pulses are output with each rotation of the motor output shaft.
16		OUT0-		
17		OUT1+	ALARM-OUT	Output when an alarm activates. (Normally closed)
18		OUT1-		

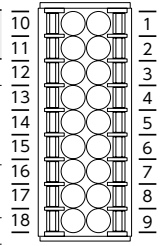

● Applicable Lead Size
AWG24~18
(0.2~0.75 mm²)

*The text inside the [] represents the factory default function assignment. Pin No. 2 - 8, 15 - 18 can change the assigned functions. Assignment points are 7 points for the 12 types of input signal and 2 points for the 7 types of output signal.

◇ Reassignable Signals

Signal Type	Function	Description
Input	START/STOP	The motor rotates when the START/STOP input and RUN/BRAKE input are ON. The motor decelerates to a stop when START/STOP input is turned OFF.
	RUN/BRAKE	
	CW/CCW	This signal switches the motor's rotation direction.
	M2	This signal selects the operating data number.
	M3	
	H-FREE	The easy hold is cancelled when the H-FREE input is ON.
	TL	This signal enables and disables torque limiting from the outside.
HMI	This signal limits the operation that uses a control panel or data setting software MEXE02 .	
EXT-ERROR	This signal forcefully stops the motor from the outside.	
Output Power	MOVE	This signal is output when the motor is rotating with the operation input turned ON.
	INFO	This signal is output when general information is generated.
	TLC	This signal is output when the motor's output torque has reached the torque limiting value.
	VA	This signal is output when the motor's detection speed has reached the setting speed \pm VA detection width.
	DIR	This signal outputs the motor's rotation direction.

● Connection Diagram

This is a connection example for single-phase 200-240 VAC when setting the speed from the outside. The I/O signal inside [] is the factory setting.

◇ Using Built-in Power Supply

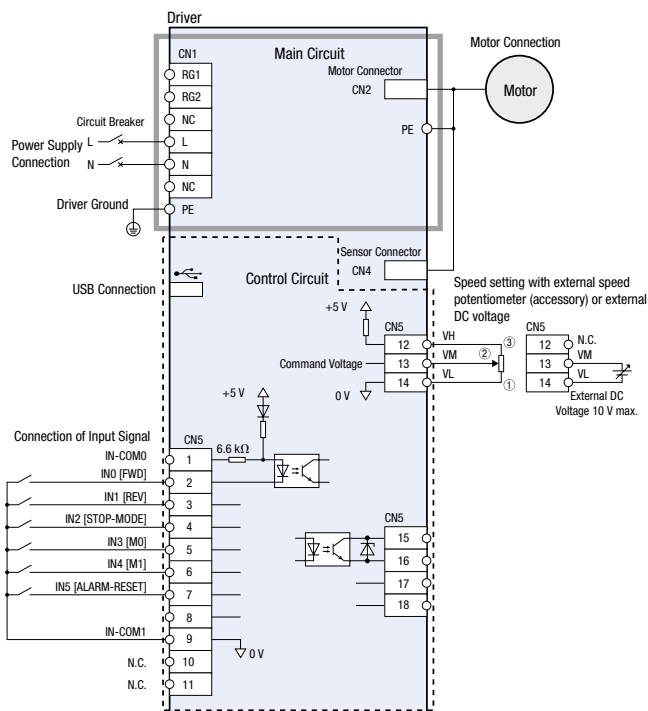

◇ Using External Power Supply

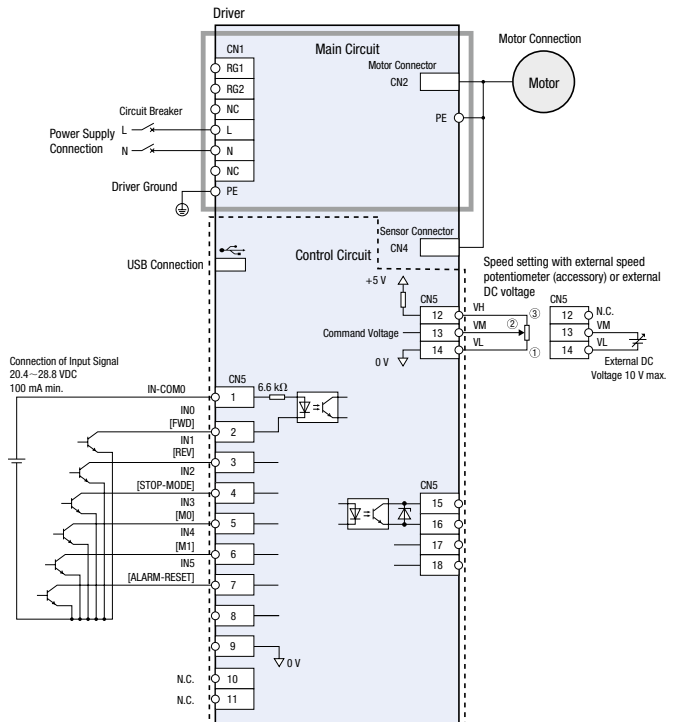

● Timing Chart (2-wire input method)

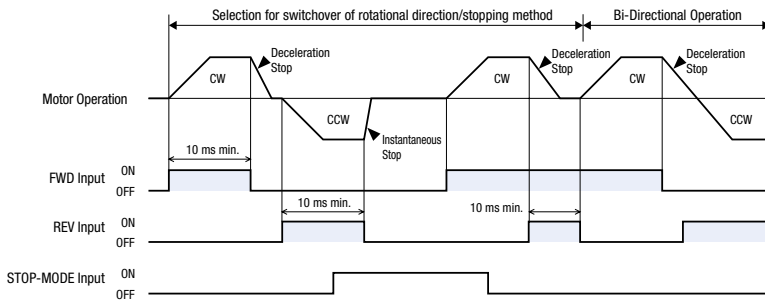

● FWD Input, REV Input

When FWD input is ON, it rotates in CW direction (clockwise). Turning it OFF decelerates the motor to a stop.

When REV input is ON, it rotates in CCW direction (counterclockwise). Turning it OFF decelerates the motor to a stop.

● STOP-MODE Input

It selects the method for stopping the motor when FWD input and REV input are turned OFF.

When the STOP-MODE input is OFF, the motor decelerates to a stop according to the deceleration stop of the operating data number.

When STOP-MODE is ON, it stops at the shortest time (instantaneous stop).

● I/O Signal Circuits

Select the sink logic or source logic wiring according to the external control device that will be used.

◇ Input Signals

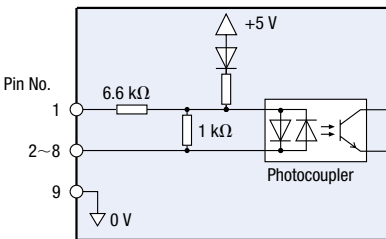

◇ Output Circuit

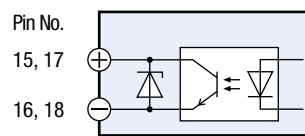

◇ Programmable Controller Connection Examples

● Sink Logic

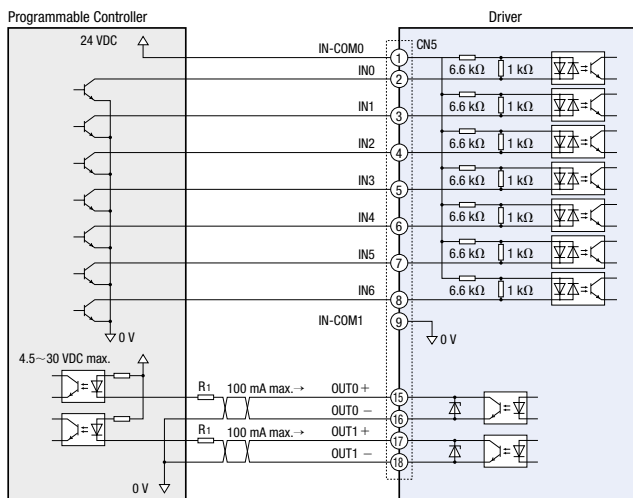

● Source Logic

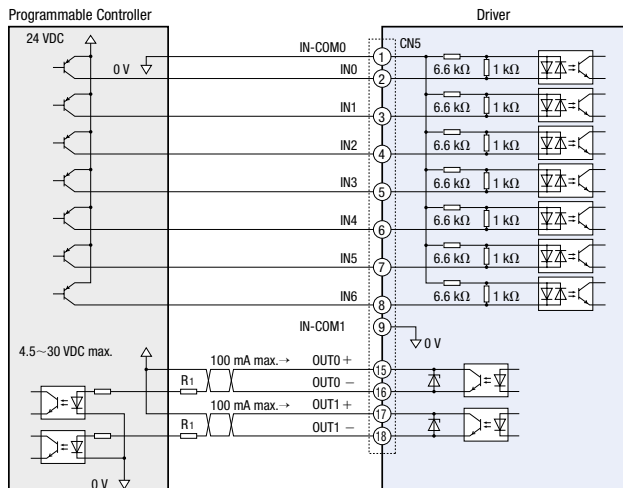

◇ When an External Control Device with a Built-In Clamp Diode is Used

If an external control device with a built-in clamp diode is connected and the external control device is turned off when the driver power is on, current may flow in and rotate the motor.

Because the current capacity of the driver and external control device is different, the motor may also rotate when their power supplies are turned ON or OFF simultaneously.

To turn the power off, turn off the driver and then the external control device. To turn the power on, turn on the external control device and then the driver.

● Example of Sink Logic

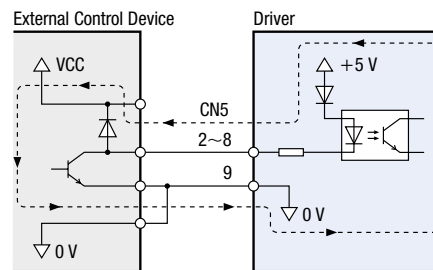

◇ SPEED-OUT

Pulse signals of 30 pulses (pulse width: 0.2 ms) are output per each rotation of the motor output shaft in synchronization with the motor operation.

The speed output frequency can be measured and the approximate motor speed calculated.

$$\text{SPEED-OUT Frequency [Hz]} = \frac{1}{T [\text{s}]}$$

$$\text{Motor Shaft Speed [r/min]} = \frac{\text{SPEED-OUT Frequency [Hz]}}{30} \times 60$$

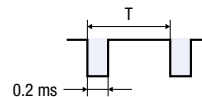

◇ ALARM-OUT

When any of the driver's protective functions is activated, the output turns OFF and the ALARM LED blinks. An alarm code will be displayed on the control panel and the motor will coast to a stop.

● Speed Setting Methods

Speed can be set using the following 4 methods.

◇ Using the control panel



◇ Using the external speed potentiometer

Connect an external speed potentiometer to the I/O signal connector (CN5) of the driver.

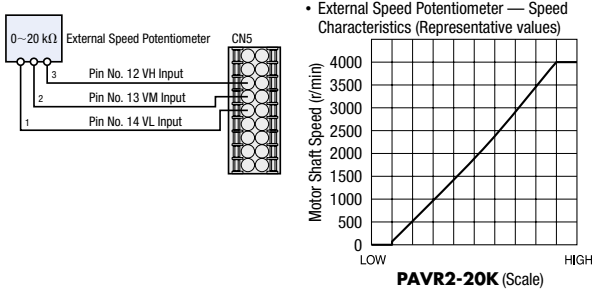

Note

● The speed in the graph represents the speed of the motor alone. The output gear shaft speed of the combination type is calculated by dividing the graph speed by the gear ratio.

◇ Set using external DC voltage

Connect external voltage to the I/O signal connector (CN5) of the driver.

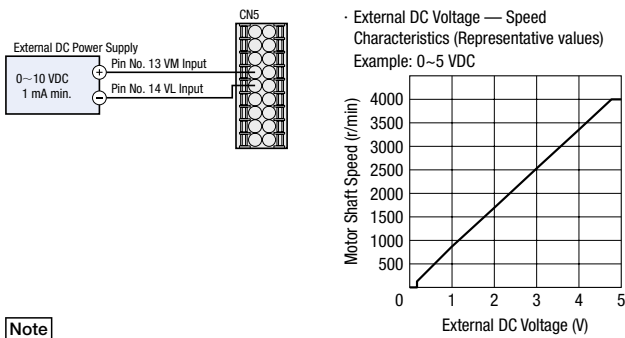

Note

● It can be set at 0-10 VDC.

● The speed in the graph represents the speed of the motor alone. The output gear shaft speed of the combination type is calculated by dividing the graph speed by the gear ratio.

◇ Using Data Setting Software (MEXE02)

PC that has data setting software (MEXE02) installed

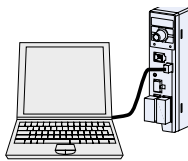

● Multiple Speed-Change Operation (Max. 16 speeds)

Operation data number is selected by combining the M0~M3 input ON/OFF.

Operating Data Number	M3	M2	M1	M0
0	OFF	OFF	OFF	OFF
1	OFF	OFF	OFF	ON
2	OFF	OFF	ON	OFF
3	OFF	OFF	ON	ON
4	OFF	ON	OFF	OFF
5	OFF	ON	OFF	ON
6	OFF	ON	ON	OFF
7	OFF	ON	ON	ON
8	ON	OFF	OFF	OFF
9	ON	OFF	OFF	ON
10	ON	OFF	ON	OFF
11	ON	OFF	ON	ON
12	ON	ON	OFF	OFF
13	ON	ON	OFF	ON
14	ON	ON	ON	OFF
15	ON	ON	ON	ON

● Parallel-Motor Operation

Multiple motors can be operated at the same speed using 1 potentiometer or external DC voltage.

The figure below shows an example of the single-phase power supply specification. For a three-phase specification, change the power supply line to a three-phase power supply. The motor operation control unit is not illustrated in the figure.

◇ Using a Potentiometer

When using a potentiometer (VRx), operate with 20 units or less.

Resistance value when the number of drivers is n:

$$VRx = 20/n \text{ (k}\Omega\text{)}, n/4 \text{ (W)}$$

Example: When 2 drivers are connected

$$VRx = 20 \text{ k}\Omega/2 = 10 \text{ k}\Omega; P = 2/4 \text{ W} = 0,5 \text{ W}$$

Selected potentiometer: 6,8 kΩ; 0,25 W.

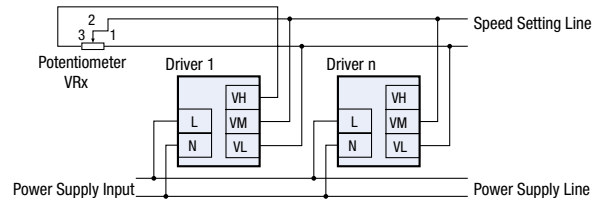

◇ Using External DC Voltage

The power supply capacity of the external DC power supply is determined as follows.

Power supply capacity when the number of drivers is n:

$$I = 1 \times n \text{ (mA)}$$

Example: When 2 drivers are connected

$$I = 1 \times 2 = 2 \text{ (mA)}$$

Power supply capacity is 2 mA min.

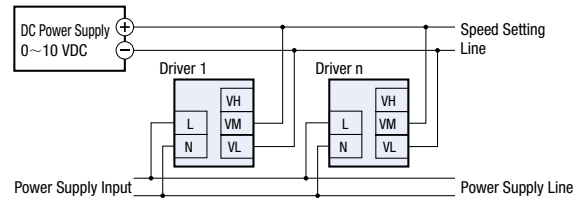

Accessories (Sold separately)

● Cable System Configuration

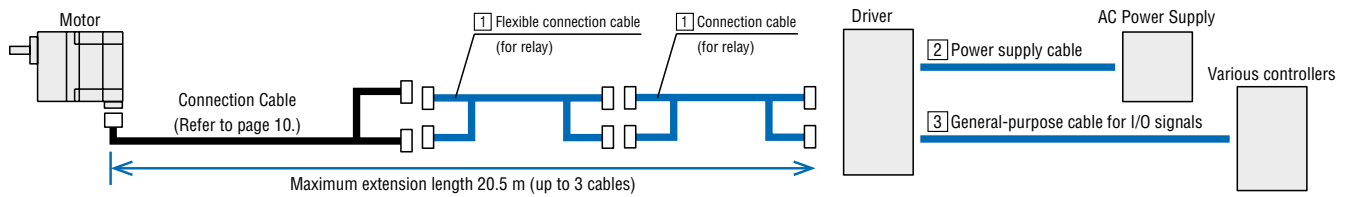

1 Connection Cable (for relaying), Flexible Connection Cable (for relaying)

When extending the cable by adding connection cables (for relaying)/flexible connection cables (for relaying), ensure that the overall length of the cable is 20.5 m max (up to a total of 3 cables).

● Product Line

◇ Connection Cables

Product Name	Length L [m]	List Price
CC01BL2	1	27.00 €
CC02BL2	2	38.00 €
CC03BL2	3	49.00 €
CC05BL2	5	71.00 €
CC07BL2	7	92.00 €
CC10BL2	10	125.00 €



◇ Flexible Connection Cables

Product Name	Length L [m]	List Price
CC01BL2R	1	54.00 €
CC02BL2R	2	76.00 €
CC03BL2R	3	98.00 €
CC05BL2R	5	141.00 €
CC07BL2R	7	184.00 €
CC10BL2R	10	250.00 €



2 Power Supply Cable

These cables are used to connect the driver and the AC power supply. Cables are available with or without a power supply plug.



Plug Included

● Product Line

Product Name	Power Supply Voltage	Length L [m]	List Price
CC01AC03N	Single-Phase 100-120 VAC	1	10.00 €
CC02AC03N		2	15.00 €
CC03AC03N		3	20.00 €
CC01AC04N	Three-Phase 200-240 VAC	1	10.00 €
CC02AC04N		2	15.00 €
CC03AC04N		3	20.00 €

3 General-Purpose Cables for I/O Signals

These cables connect the driver and programmable controller.



● Product Line

Product Name	Length L [m]	Number of Lead Wire Cores	Outer Dimensions D [mm]	AWG	List Price
CC06D005B-1	0.5	6	φ5.4	24	12.00 €
CC06D010B-1	1				14.00 €
CC06D015B-1	1.5				15.00 €
CC06D020B-1	2	16.00 €			
CC10D005B-1	0.5	10	φ6.7		14.00 €
CC10D010B-1	1				16.00 €
CC10D015B-1	1.5				17.00 €
CC10D020B-1	2	19.00 €			
CC12D005B-1	0.5	12	φ7.5		15.00 €
CC12D010B-1	1				17.00 €
CC12D015B-1	1.5				20.00 €
CC12D020B-1	2	22.00 €			
CC16D005B-1	0.5	16	φ7.5	16.00 €	
CC16D010B-1	1			18.00 €	
CC16D015B-1	1.5			21.00 €	
CC16D020B-1	2	23.00 €			

Note

An external speed potentiometer (**PAVR2-20K**) and a general-purpose cable for I/O signals cannot be used together.

Flexible Coupling

This is a clamp type coupling for connecting the motor and gearhead shaft with a driven shaft.

- It can be used on a round shaft type as well. Please select a coupling with an inner diameter that matches the motor shaft's diameter.



Product Line

Applicable Product	Load Type	Couplings Type	List Price
BLM230	Uniform Load	MCL30 Type	36.00 €
	Impact Load		
BLM460	Uniform Load	MCL40 Type	55.00 €
	Impact Load	MCL55 Type	72.00 €
BLM5120	Uniform Load	MCL55 Type	72.00 €
	Impact Load		
BLM6200, BLM6300	Uniform Load	MCL65 Type	115.00 €
	Impact Load		

External Speed Potentiometer

Features

- A Potentiometer that can adjust speed and torque.
- Easy Installation
Simply insert it into the installation hole without using any tools. It can also be removed easily.
- Easy Wiring
It uses terminal blocks. It requires no soldering for connecting lead wires. This improves the work efficiency of the wiring.



<Front Face>



<Rear Face>

Product Line

Product Name	List Price	Applicable Product
PAVR2-20K	17.00 €	BLE2 Series, BXII Series, BLH Series, DSC Series

The following items are included with each product.
External Speed Potentiometer, Operating Manual

Note

An external speed potentiometer (**PAVR2-20K**) and general-purpose cable for I/O signals cannot be used together.

Specifications

Resistance: 0~20 kΩ
Rated Power: 0.05 W
Resistor Variable Characteristics: B curve

Applicable Lead Wire Size*

AWG22~18 (0.3~0.75 mm²)

*When combined with **BLE2** Series

Motor and Gearhead Installation Bracket

These dedicated installation brackets are convenient for installing and fixing motors and gearheads.



Product Line

Product Name	Applicable Product	List Price
SOL2M4F	BLM230, BLM260 (Round shaft type)	20.00 €
SOL4M6F	BLM460 (Combination type)	23.00 €
SOL5M8F	BLM5120, BLM5200, BLM5300 (Round shaft type)	25.00 €
SOL6M8F	BLM6200, BLM6300 (Combination type)	27.00 €

Note

When fixing the mounting brackets and motors, ensure that the motor connector is facing upwards or sideways with respect to the installation surface.

Installing with the motor connector facing downwards is not recommended as this will interfere with the mounting brackets and installation surface.

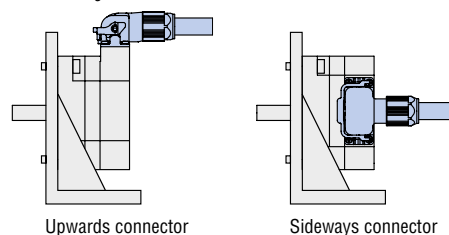

DIN Rail Mounting Bracket

Use DIN rail mounting brackets to install a driver to a DIN rail.



Product Line

Product Name	List Price	Applicable Product
MADP02	19.00 €	BLE2 Series, BXII Series, BLH Series (100 W)

For details, check the website or contact the customer support center.

<http://www.orientalmotor.eu>

Motor Cover NEW

This cover protects the motor. They are compatible with the degree of protection IP66 specification, and can be used in wet and dusty environments.

Product Line

Motor Cover

Product Name	List Price
PCMS	30.00 €
PCMS-C	37.00 €



Replacement Gasket

Replace the gasket approximately once a year.

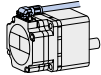

Product Name	List Price	Set contents
PCMP5	6.00 €	Set of 2 gaskets

Applicable Product

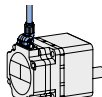
Output Power [W]	Motor	Cable Pull-out Direction
30, 60, 120	Parallel Shaft Combination Type*	Pull-out on output shaft side 
	Round Shaft Type	Pull-out on rear of the motor 
	Parallel Shaft Combination Type* Round Shaft Type	Vertical Pull-out 

*Parallel shaft combination type cannot be used for pull-out on rear of the motor.

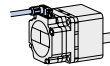

With Brush Cap
PCMS



With a Cable Gland
PCMS-C

For details, check the website or contact the customer support center.

<http://www.orientalmotor.eu>

Introduction of Related Products

Brushless Motor and Driver Packages

BMU Series



The **BMU** Series: Excellent ease of use with a setting dial for easy speed control, easy wiring, etc.

There is also a new connector type that allows for direct connection between the motor and driver.

The highest standard in speed control at an affordable price.

●Features

- Easy Speed Control by Turning and Pressing Dial
- Easy Wiring, Easy Set Up
- Compact, High Power and High Efficiency Motor
- Speed Control Range 80~4000 r/min
- Speed Regulation (Load) $\pm 0.2\%$
- Load Factor Indication and Alarm Indication are Possible
- Multistep Speed-Change Operation up to 4 Speeds is Possible
- Acceleration/Deceleration Time Can be Set
- Output Shaft Holding when Stopped

Orientalmotor

These products are manufactured at plants certified with the international standards **ISO 9001** (for quality assurance) and **ISO 14001** (for systems of environmental management).

Specifications are subject to change without notice. Published in September 2021

ORIENTAL MOTOR (EUROPA) GmbH

www.orientalmotor.de

European Headquarters

Schiesstraße 44
40549 Düsseldorf, Germany
Tel: 0211-520 670 0 Fax: 0211-520 670 99



Spanish Office

C/Caléndula 93 - Ed. E - Miniparc III
28109 El Soto de La Moraleja,
Alcobendas (Madrid), Spain
Tel: +34 918 266 565
www.orientalmotor.es

ORIENTAL MOTOR (UK) LTD.

www.oriental-motor.co.uk

UK Headquarters

Unit 5, Faraday Office Park,
Rankine Road, Basingstoke,
Hampshire RG24 8AH, U.K.
Tel: 01256-347 090 Fax: 01256-347 099



ORIENTAL MOTOR SWITZERLAND AG

www.orientalmotor.ch

Switzerland Headquarters

Badenerstrasse 13
5200 Brugg AG, Switzerland
Tel: 056-560 504 5 Fax: 056-560 504 7



ORIENTAL MOTOR ITALIA s.r.l.

www.orientalmotor.it

Italy Headquarters

Via XXV Aprile 5
20016 Pero (MI), Italy
Tel: 02-939 063 46 Fax: 02-939 063 48



ORIENTAL MOTOR (FRANCE) SARL

www.orientalmotor.fr

France Headquarters

56, Rue des Hautes Pâtures
92000 Nanterre, France
Tel: 01-478 697 50 Fax: 01-478 245 16



Other countries: www.orientalmotor.eu

Customer Service Center (Support in German & English)

00800-22 55 66 22*
CA LL OM CC

Mon-Thu: 08:00 - 16:30 CET Friday: 08:00 - 15:00 CET

*Free Call Europe

info@orientalmotor.de

For more information please contact: